

TYPICAL WIRING DIAGRAM

Turn Signal Switch With Integral Pilot Lamps

TYPICAL GROTE TSS WIRING DIAGRAM

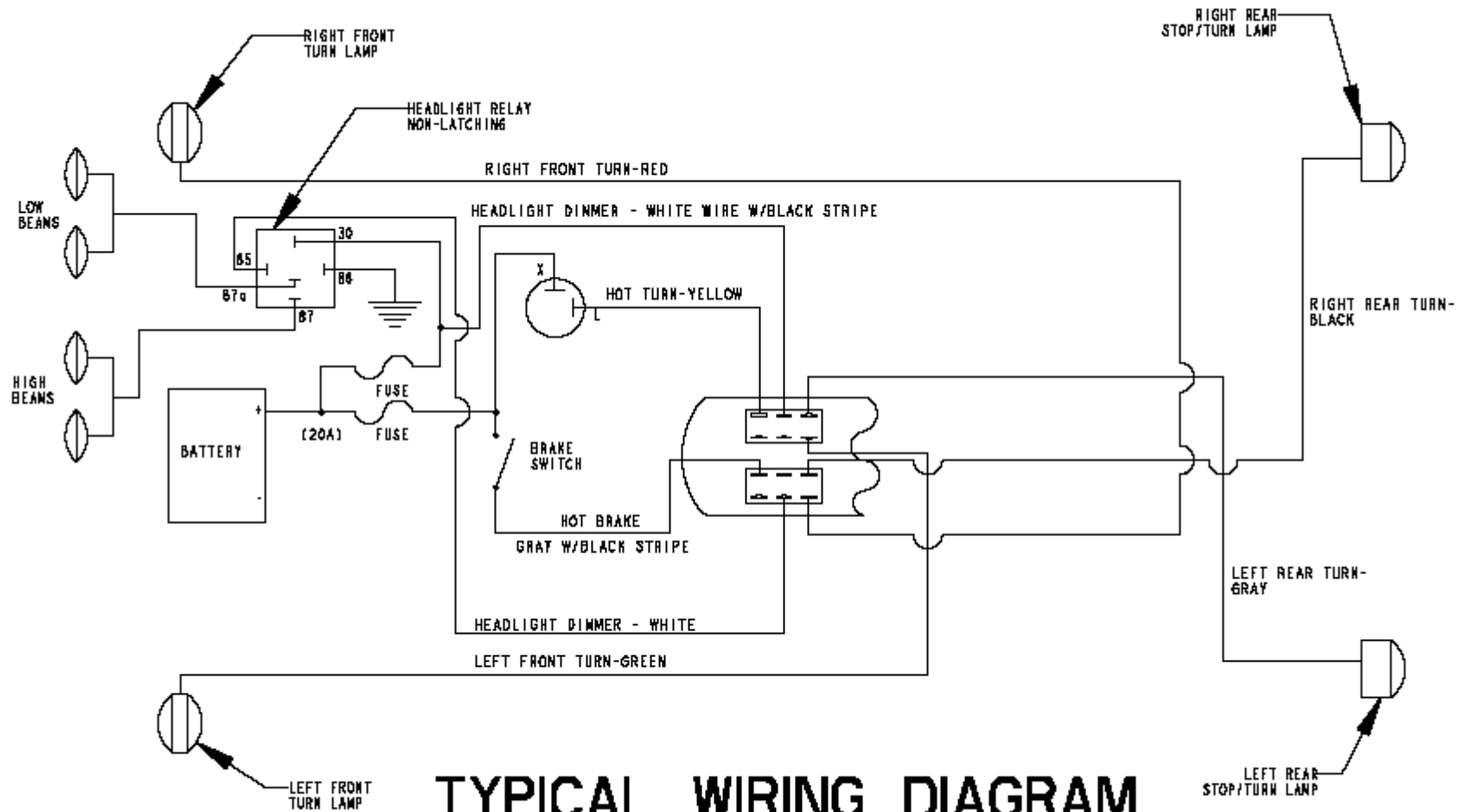

TYPICAL WIRING DIAGRAM

CONTINUITY DIAGRAM

FUNCTIONS	1	2	3	4	5	6	7	8	9	10	11	12
HEADLIGHT DIMMER		●									●	
STOP - RIGHT REAR							●		●			
STOP - LEFT REAR			●				●					
TURN - LEFT REAR	●		●									
TURN - LEFT FRONT	●					●						
TURN - RIGHT REAR	●								●			
TURN - RIGHT FRONT	●											●
HAZARD ON	●		●			●			●			●

TYPICAL TSS TERMINAL LOCATION DIAGRAM

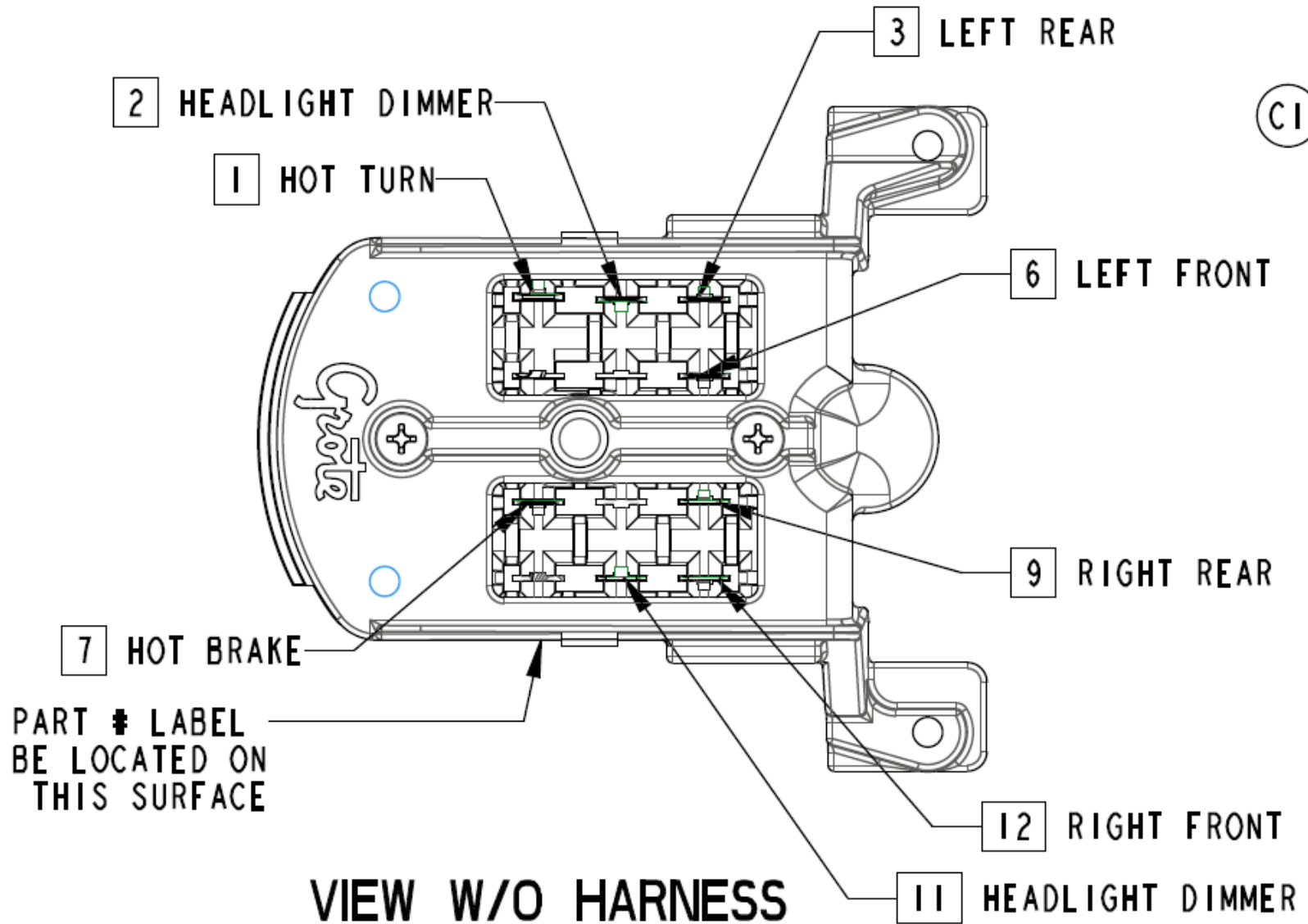

GROTE TSS MAXIMUM LOADS

Left Front: 10 Amps at 12.8 Volts

Right Front: 10 Amps at 12.8 Volts

Left Rear: 10 Amps at 12.8 Volts

Right Rear: 10 Amps at 12.8 Volts

Brake: 10 Amps at 12.8 Volts

Dimmer: 1 Amp at 12.8 Volts

Flash To Pass: 1 Amp at 12.8 Volts

Wiper: 1 Amp at 12.8 Volts

Note: Turn and Hazard Override Brake