

*Know-How*

Series of Self-Study Guides  
from Grote Industries

# Vehicle Lighting Installation and Troubleshooting

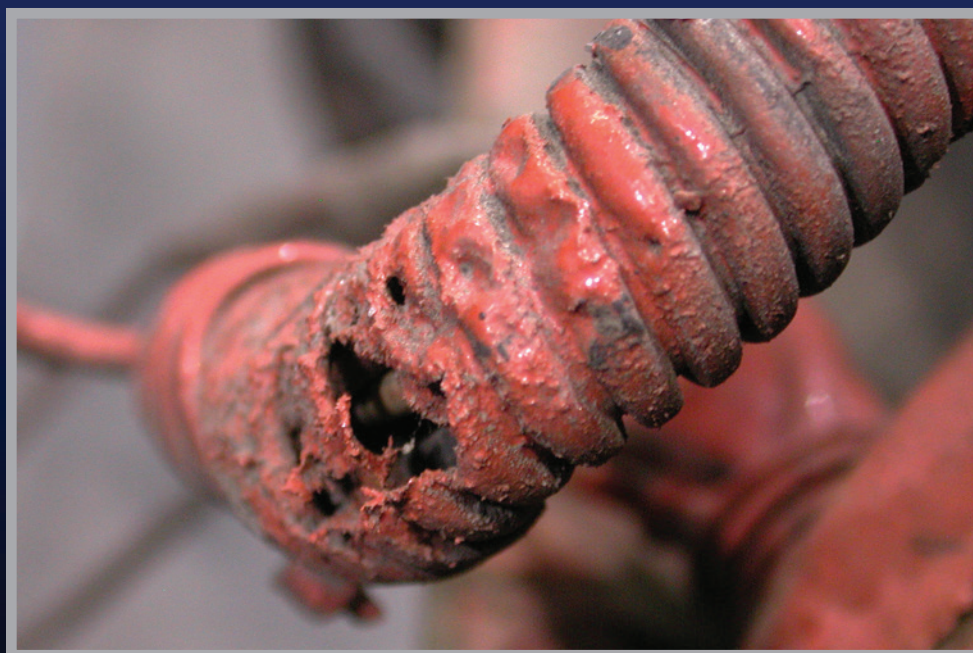

**Grote**<sup>®</sup>

## How To Use This Book

This self-study guide is divided into eight sections that cover topics from installation and troubleshooting to battery maintenance and inspection. It presents the information in text form supported by illustrations, diagrams charts and other graphics that highlight and explain key points. Each section also includes a short quiz to give the you a measure of your comprehension. At the end of the guide is a final test that is designed to measure the learner's overall comprehension of the material.

To get the most value from this study guide, carefully read the text and study the illustrations in each section. In some cases, you may want to underline or highlight key information for easier review and study later. This guide is designed to be effective for a variety of learning styles and speeds. Material can be read and studied a section at a time, a few pages at one time or even completed in one study session.

Once a section is completely read, use the quiz to determine your level of success in understanding the material. If you choose the wrong answer to a question, be certain to turn back to the relevant material in the section and re-read and re-study the information.

To use the quiz effectively, use a sheet of paper positioned so that it covers all of the quiz material except for the first question. Choose your answer. Then move the sheet

down to expose the first line of the second question. The answer to the first question is shown at the far right. Compare your answer to the answer key.

Choose an answer to the second question. Slide the cover sheet down to expose the first line of the third question and compare your answer to the answer key.

In the same manner, answer the balance of the quiz questions.

The final exam at the end of this guide presents a second test of your knowledge of the material. Be certain to use the quizzes and final exam. In the case of the final exam, fold the answer sheet as directed, and mail to the address indicated for scoring.

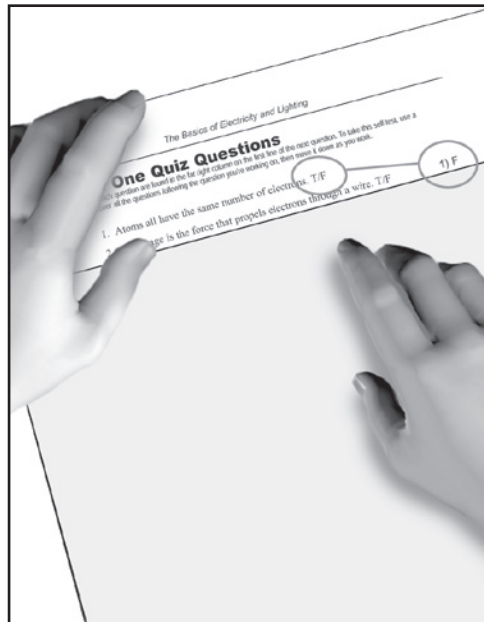

## CONTENTS

The E.A.T. Principle .....	2
Quiz Questions .....	8
Environmental Factors .....	10
Quiz Questions .....	20
Wiring Protection .....	24
Quiz Questions .....	30
System Troubleshooting .....	32
Quiz Questions .....	39
Troubleshooting Trailer Wiring Harness Systems .....	42
Quiz Questions .....	50
Troubleshooting Batteries and Battery Cables .....	52
Quiz Questions .....	66
Lighting Failure Checklist .....	70
Quiz Questions .....	75
Choosing The Right Wire .....	76
Quiz Questions .....	86
Final Exam .....	88
Answer Sheet .....	95

## Grote Know-How

This book is the second in the Grote *Know-How* series of self-study guides. These training courses are designed for counter sales people as well as those who work in the shop servicing trucks and trailers.

The first book in the series it called “the Basics of Electricity and Vehicle Lighting.” If you haven’t taken that

course yet, we recommend it as a prelude to this book since it contains basic information on electricity, wiring, types of lamps used and proper tools for the job.

These books are designed as self-study guide for individual learning programs, but can be used effectively in a classroom setting. We are pleased to offer them as a service to our valued customers.

## **Section One**

### **Mastery Statement**

When you have successfully completed this section, you will have mastered the following:

- The E.A.T. effects as they apply to vehicle lighting and wiring
- Steps to prepare for installation, troubleshooting and repairs
  - Tools
  - Supplies
  - Work environment
  - Vehicle inspection

## The E.A.T. Principle

*There's no doubt that, of all the systems on a typical vehicle, the lights and wiring are among the most subject to wear and tear. Operating in harsh weather conditions, open to a variety of damaging environments such as loading docks and yards, and subject to vandalism, a significant amount of repair time and effort is often required. This chapter will introduce you to some of the most common problems associated with lighting systems and review some of the basic tools and procedures to prepare for installation, troubleshooting and repairs.*

### **The “E. A.T.” principle**

Three of the most often cited factors in vehicle light and wiring damage are:

- Environment
- Abuse
- Time

Those factors are the same ones at work on the electrical systems of buildings. Both systems, when inspected and maintained regularly, last longer and have fewer problems. The environment that any wiring lives in is critical to its proper performance and durability. In buildings, because they are contained in the walls, there is more protection for wire and cable, especially where conduit is used.

But both systems are vulnerable to abuse. For instance, wiring is designed to carry a specified electrical load. Increasing the load beyond the designed tolerance of the wire can lead to increased heat and the possibility of fire.

Time is another factor that affects wiring. Even the best building systems are subject to degradation over time. But it's worse with vehicle wiring because vehicles tend to operate in harsher environments.

Trailers run year-round in climates ranging from desert heat to sub-zero cold. Road salt, magnesium chloride, calcium chloride and similar chemicals coat trailer components as trucks plow through puddles of melt-water splashing corrosive mixtures on the lights, connectors and



The E.A.T. Principle  
The three factors that take the biggest “bite” out of truck wiring and lighting are Environmental factors, Abuse and Time.



Eleven times more salt is put on the nation's roads in a year than is used in seasoning and food preparation.

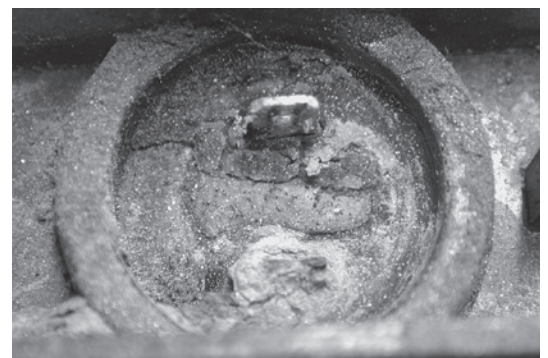

The lower terminal on this lamp became so badly corroded that it broke off.

wiring. Eleven times more salt is put on the nation's roads in a year than is used in seasoning and food preparation. When salt water enters a wiring system through a cut, an abrasion or a faulty connection, it begins a process known as "salt creep." The salt works its way along the wire and settles in critical junctions. Allowed to go unchecked, salt creep will eventually produce an intermittent defect or a total failure.

Vibration, often severe, is a constant threat as a trailer rolls along the road. Every component and all of the connections are constantly subjected to the pounding and loosening effects of vibration. Wiring connections are especially prone to damage from vibration.

Failure from abuse can be traced to a number of causes, but a few simple ones cause most of the problems. For instance, using a wire size too small for the task, such as supplying power to too many lights on a circuit, can cause substandard light output, overheating of the wiring or total failure.

Another common abuse of the wiring system is the use of numerous splices of smaller lengths instead of one piece of properly sized wire. Extra connections open the door to excess resistance, poor-quality connections and the failure of the circuit.

Another common problem is the failure to use appropriate protection for the connections and the wire itself. An example of this might be the failure to use shrink tubing to protect a splice from the elements or assembling system elements without using dielectric coating.

The effects of environment and abuse just get worse with time. One or two scrapes of a wire on a rough metal edge may not cause a failure. But a single trip over a typical highway could be enough to cause a grounded circuit and a lamp failure. Similarly, water and salt splashed on a connection once or twice may not cause immediate failure. However, constant exposure can accelerate the pace of damage so that one trip could easily cause salt creep and lead to the failure of a circuit.

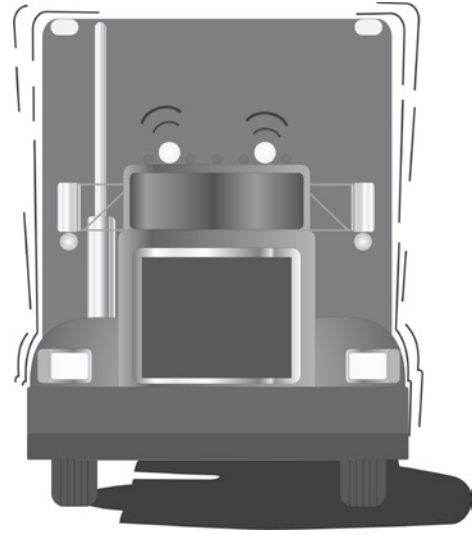

Vibration is a constant threat to truck and trailer lighting and wiring.



Too many splices, and splices with inadequate protection are a source of problems.

### ***Preparation For Installation, Repair & Troubleshooting***

One of the most important factors in successfully installing, repairing and troubleshooting lights and wiring is quality workmanship. That means anticipating the requirements of the job at hand and having everything needed before you start. The following is a short list of the things that will make your work easier and faster.

#### ***Tools***

Many of the tools needed for working on wiring systems are ordinary hand tools. Side cutters and standard wire cutters are basic necessities for most wiring projects. Another indispensable wiring tool is a wire stripper for providing clean, accurate removal of insulation from the conductor. For disassembling wiring, installing new devices and tightening components loosened from vibration a good selection of screwdrivers is indispensable.

For most installation and repair work where shrink tubing is to be used, a heat source is required to activate the tubing. The best tool is a heat gun. It provides heated air that can be easily directed to the connection. Some technicians prefer a butane torch for this task, although care must be exercised to avoid burning the tubing and wire insulation.

Another important tool category is testers. Every toolbox should have a continuity tester. It's used to indicate whether a circuit is complete and unbroken. By testing sections of wire, it's possible to isolate the source of the problem. The other common tester is the multi-meter. It functions as an ammeter measuring current flow, a voltmeter measuring volts and an ohmmeter measuring resistance in a circuit. Many multi-meters also function as continuity testers.

A simple but necessary tool that's a real asset on many jobs is a flashlight. Since vehicle wiring is frequently not readily accessible and in the shadows, a flashlight becomes a tool that technicians rely on, especially in the diagnostic phase. In a pinch a flashlight can be a continuity tester. Using a short length of wire, open the flashlight and connect it in series with circuit you're testing.

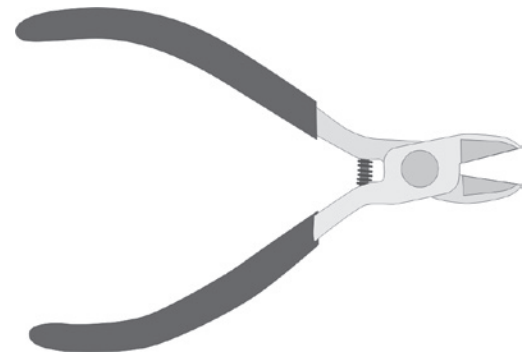

Wire Cutters

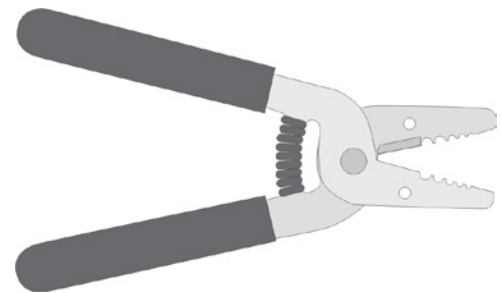

Wire Strippers



Digital Multimeter

## Supplies

In addition to the tools, gather the supplies required for the job. Dielectric coating is an indispensable product for anyone doing installation and repairs to lighting and wiring. It's applied to connections that are exposed to water and humidity. When applied, it keeps out moisture, extending the service life of the connections.

Shrink tubing is another item that offers substantial protection for connections and should be a basic item in wiring projects. By choosing the right type, shrink tubing can add mechanical strength to a connection, protection from contaminants or both.

Loom, flex tubing and spiral wrap provide convenient and effective means of containing and routing wires. Similarly, wire ties and clamps are useful for securing wire and cables. Using these products will go a long way toward protecting wires that might otherwise become snagged or rub against sharp edges on the vehicle.

In situations where wires must be replaced, make sure you use the right gauge. Remember, if you increase either the length of run or the load, you will also increase the resistance in the circuit and the amount of heat generated. In such cases, it may become necessary to use a larger gauge of wire.

The last category of supplies is electrical connectors. It's important to have them on hand to replace all connectors removed from the vehicle. Used connectors can harbor corrosion. They may fit poorly causing inferior contact with the conductor and create excess resistance. Or they may simply fail due to age and allow the wires to disconnect.

## Working Environment

Installing and repairing lighting and wiring should be done in an environment that minimizes contamination. A clean and well-organized work area makes it easier to keep tools and parts clean and free of water, dust, oil and grease.

And always take precautions to avoid injury. Wear safety eyewear and use gloves to protect against sharp edges. Always work in an environment that's well lit so you can see wire markings, product identification numbers and other details.



Dielectric coating is an indispensable product for anyone doing installation and repairs to lighting and wiring.



Shrink tubing comes in a wide variety of sizes.

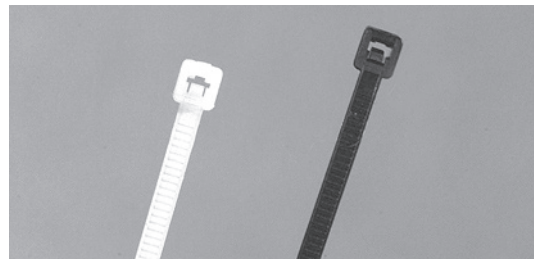

Wire ties in different colors can be used to color-code wire bundles.



Wire clamps in a variety of styles and materials hold wires securely in place while reducing flex and bounce from vibration.



### ***Inspect the Vehicle***

A few minutes spent inspecting the vehicle can pay off in time saved in the repair or installation process. A quick walk around may offer clues as to what's causing the reported failure as well as clues as to other potential problems. For example, visible dried and cracked insulation indicates the likelihood of a grounded or short circuit. Oil soaked wiring is a sign that there may be deterioration of the insulation. Check all exposed harnesses and wiring, including the all-important battery cables.

Visually check the routing of the wiring. Look for wires that are in contact with sharp metal, and add protective grommets where they are missing. Also look for wires stretched tightly with no strain relief, a condition that may result in connections loosening up or separating completely.

Check for visible signs of damage to lighting devices. Cracks and abrasions indicate that even though the unit hasn't failed, it may be providing substandard performance and be ready to fail at any moment. At the very least, damaged units ought to be inspected for signs of faulty mounting, broken lamps and damaged connections.

Check for visible signs of corrosion buildup on all devices and connections. Even small deposits indicate the presence of corrosive salt and chemicals. The connections have probably become unsealed. Corrosion also suggests that contaminants have worked their way in through wires from a point where the insulation was cut or scraped open. In any case, the result is future failure.

### ***Starting Installation or repair***

Carefully hook up power to the trailer.

Make sure that you have all tools, testers and supplies ready. Never use the pointed tip of the tester to puncture the insulation on the wire you are testing. Even a tiny hole may allow the entrance of moisture and corrosive agents that can migrate from that point to other areas of the wiring assembly such as connections and splices or to the lighting devices themselves. Eventually that tiny hole can render the system inoperative.

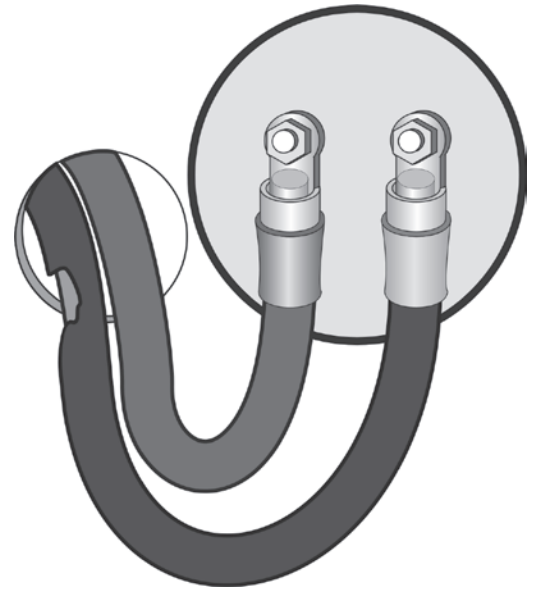

Visually inspect the truck for wires that are in contact with sharp areas of metal.



Never use the pointed tip of the tester to puncture the insulation on the wire you are testing.

## Section One Quiz Questions

1. The E.A.T. principle refers to:
  - a) Assessment of corrosion
  - b) Environment and abuse
  - c) Environment, Abuse and Trouble shooting process for wiring and lighting
  - d) None of the above
  
2. Adding more lights to a circuit without increasing the wire gauge may cause a fire. T/F **1. d**
  
3. Unlike home wiring, vehicle wires are less prone to damage because they are visible and not contained in walls. T/F **2. T**
  
4. “Salt creep” refers to: **3. F**
  - a) The coating of wires in salt spray from the front of a trailer to the rear.
  - b) Salt that works it’s way inside a wire after entering at a cut, abrasion, or faulty connection.
  - c) A condition remedied by washing trailer wiring often.
  - d) All of the above.
  
5. Splicing several smaller pieces of wire in a circuit is better than a single length of wire. T/F **4. b**
  
6. It takes many years for the effects of time to damage the lights and wiring on a trailer. T/F **5. F**
  
7. The best tool for applying heat to shrink tubing is a: **6. F**
  - a) Butane torch
  - b) Hot air heat gun
  - c) Heat lamp
  - d) None of the above
  
8. At the very least, a toolbox ought to have a: **7. b**
  - a) Volt meter
  - b) Millimeter
  - c) Continuity tester
  - d) None of the above

**8. c**

9. The principle thing to remember about wire gauge is:
- a) The longer the run and the greater the load, the larger the wire needed.
  - b) The longer the run and the greater the resistance.
  - c) The longer the run, and the greater the load, more heat generated.
  - d) All of the above.
10. Connectors shouldn't be re-used because they may: **9. d**
- a) Fit poorly
  - b) Harbor corrosion
  - c) Simply fail and allow wires to disconnect
  - d) All of the above.
11. A coating of oil on wiring helps eliminate corrosion. T/F **10. d**
12. A walk around a tractor-trailer can often help indicate: **11. F**
- a) Battery cables that need replacement
  - b) Dried and cracked insulation
  - c) Corrosion beginning to form on connections and lights
  - d) All of the above.
13. An acceptable diagnostic technique is to use the pointed end of a continuity tester probe to puncture the insulation on a wire which makes testing faster and easier. T/F **12. d**

**13. F**

## **Section Two**

### **Mastery Statement**

When you have successfully completed this section, you will have mastered the following:

- The basic environmental factors that effect vehicle wiring and lighting
- The effects of environmental factors on wiring and lighting
- How to minimize the damage caused by these environmental effects

## Environmental Factors

*Installing wiring is more complex than ever before. With more lights and other devices being added, just finding a secure route can be difficult. One of the main sources of problems in lighting systems is the environment in which the vehicle operates. This chapter will help you to appreciate why this is true, and what you can do to protect your lighting system against harsh environmental factors.*

There are some important issues to be aware of during both the installation and repair of wiring and lighting. Some of the most important things to keep in mind are:

- **Moisture** in the form of rain, ice, and wash water
- **Corrosion** that can destroy wire and connections
- **Abrasion** resulting from contact with rough surfaces and sharp edges
- **Impact** from road debris, rocks or vehicle equipment
- **Vibration** mostly resulting from the road conditions
- **Grit & sand** especially with construction vehicles
- **Extreme temperatures** stress parts & connections
- **Tensile loads** often from ice buildup hanging on the wires
- **Flexing** from installation (near door hinges, for example)

### **Moisture**

When moving through rain showers, there are few places where a wiring system escapes getting wet. The most typical problem from moisture is that it allows electrical current to bypass the circuitry and find its own ground. Commonly called “shorting,” this prevents lights or other devices from functioning. When a circuit fails to operate because current was diverted due to water penetration, the circuit has “shorted out.” Moisture combines with road salt, washing compounds and other ingredients to attack the vehicle and its components. It can “wick” or travel along the strands of wire and wind up many feet from the point where it entered the system.

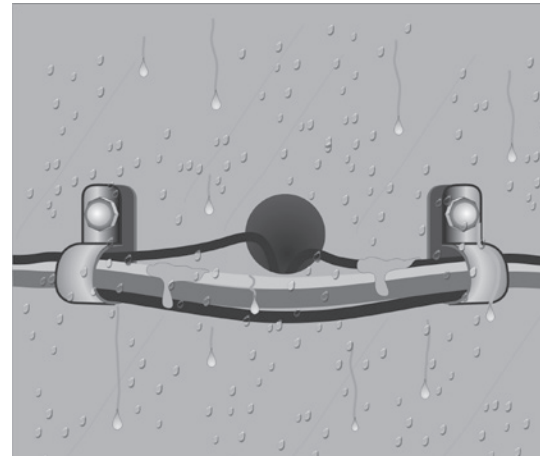

The wiring harness on a truck is constantly exposed to rain, spray, salt, snow and ice.



### **SALT CREEP**

When one end of an insulated wire is suspended in a flask of salt water, capillary action will cause the salt water to “creep” along the full length of the wire causing salt crystals to form at the other end of the wire.

Water can enter the system through ineffective wire seals, unprotected splices, unsealed crimps and connectors, non-mating seals, just to name a few of the vulnerable spots. Moisture can enter virtually any opening such as cuts or cracks in the insulation and through devices that are connected to a circuit. It can enter even through sealed wiring if driven by wind and the movement of the vehicle. It can compromise otherwise tightly sealed connections if driven by a high-pressure spray. Vibration can aid in the migration of water through seals by causing them to loosen up enough for water to penetrate. Even the difference in air pressure between the outside and the inside of the wiring system can cause water to enter. So what would cause a difference in air pressure between the inside and outside of wire? Believe it or not, this can come from a sudden change in temperature. It's been shown that as much as four pounds per square inch difference can result from rapid temperature changes from inside to outside. That fast cooling is enough to cause so-called "sealed" connections to draw in water.

There are a number of techniques to minimize problems connected with water. Most have to do with maintaining and protecting the seals at connecting points. That's why it's important to use sealed connectors wherever possible. When making repairs, don't replace a sealed system with unsealed components. Make certain that connector seals are in place and undamaged. Inspect them carefully for cuts, tears and punctures.

All wiring connections must be sealed against moisture. For example, seal areas at splices and crimps should use adhesive lined shrink tubing. Protect all connections from high-pressure spray. The force of the spray can defeat even the best seals. If the connections can't be moved out of the effects of high-pressure cleaning, be certain that they're protected using coverings such as boots, moldings, back shells, convoluted tubing, plastic loom or other sturdy, carefully installed coverings.

In addition, any unused connector should have a cap to seal out water. Wherever possible, avoid positioning wires and connectors in high splash areas. Ensure that all cover-



A sudden change in temperature can create a change in pressure of as much as 4 psi between the inside and outside of a sealed wiring system. That's enough to draw moisture into the system through any breaks in the seal.

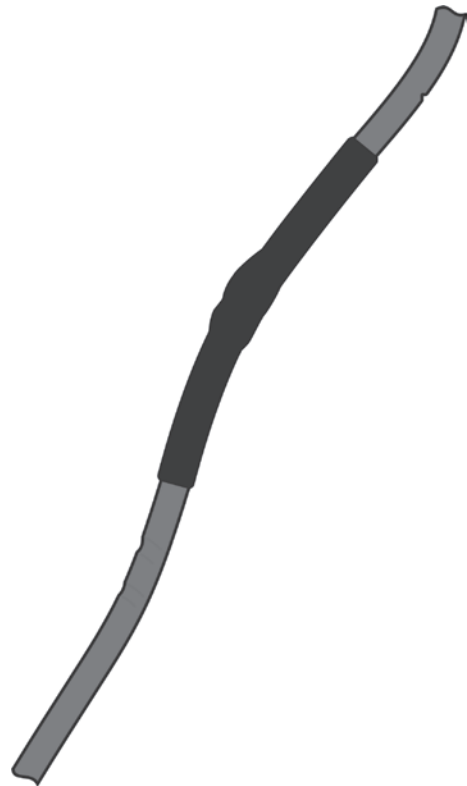

Splices should be protected with adhesive-lined heat-shrink tubing.

ings are in place and the wiring is securely fastened. This will prevent loose wire from hitting the vehicle structure and protect against damage that could allow moisture to penetrate the system. Avoid sharp bends in cable as it exits a sealed connector. A severe bend could put sufficient strain on the seals that they open up and allow moisture into the connector. Where practical, add drip loops to direct water away from connections. Never use the probe from a tester to establish contact with a wire's conductor by penetrating the insulation.

### **Corrosion**

The ingredients for corrosion are moisture and salt or similar material. It seldom occurs in dry, sealed wiring systems. The rate of corrosion's progress depends primarily upon the type of salt present, the amount of contaminant and moisture present and the susceptibility of the metal parts to corrosion. The rate may be faster under certain conditions. Galvanic reactions can speed up the corrosion process dramatically. A galvanic reaction is generated by contact between two dissimilar metals such as when a grounding ring terminal is attached to a frame member. There are other causes for corrosion, as well. Battery acid will corrode most metals used in wiring systems. So will acid rain, though not as quickly.

Corrosion produces a variety of bad effects. It can cause open circuits when a wire or other component is completely eaten away. It may cause an intermittent fault or short circuit, and very often result in increased resistance.

Recognizing corrosion is relatively easy. Copper is the most common material used as a conductor. Copper corrosion is a green or white powder-like substance. To help defend copper from corrosion, it's plated with a variety of metals such as tin, gold, nickel and silver. Mounting clips and fasteners are typically iron-based materials. They can be "passivated," a process for treating metal to reduce its reactivity. They may also be plated with zinc galvanizing.

To help avoid problems from corrosion, avoid situations where metal parts may be exposed to a wet or salt spray environment. Repair or replace covers, boots, or other protective devices. Consider re-routing wiring that's subject

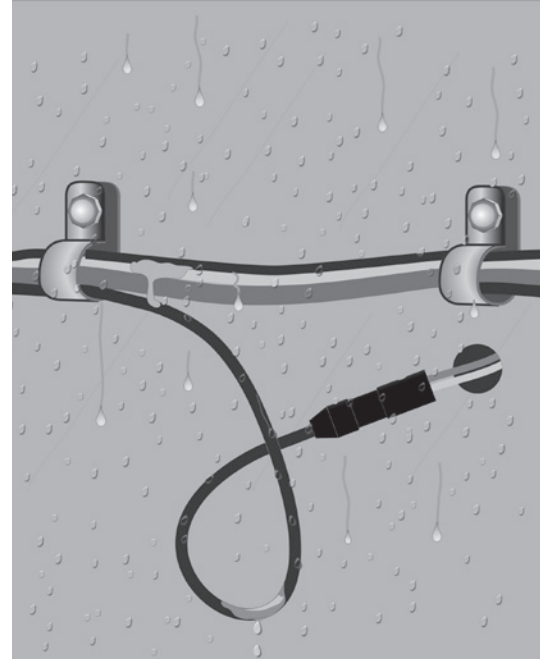

Add drain loops to direct water away from connections.

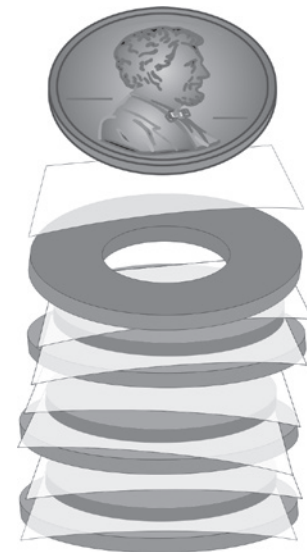

### **Galvanic Action**

You can demonstrate galvanic action by creating a galvanic battery: a stack of four pennies and four metal washers with squares of paper towel soaked with salt water between each layer. A voltmeter will detect electricity flowing from the top penny to the bottom washer. This galvanic current dramatically speeds up corrosion.

to spray, splash or battery acid. Metal parts used in wiring projects should be passivated, plated or otherwise protected from corrosion attacks.

Dielectric coatings also play an important role in sealing out both moisture and corrosive materials. Proper application of this material to sealed connections fills any voids leaving no room for moisture and other contaminants. Consistent use will add another layer of protection and help to prevent electrical system breakdowns.

### **Vibration**

The two main effects of vibration are abrasion of mating surfaces and simple failure of connections or splices to remain joined. If vibration levels are minimal, normal contact forces are enough to prevent movement of mating surfaces. Wear is minimal and few connections or splices will fail. However, if vibration levels are high, mating surfaces tend to move. In that case, terminals wear very quickly. Connection failures will be frequent, causing intermittent connections, high resistance or open circuits.

“Fretting” is a condition directly related to vibration. It’s a common wear process that occurs when vibration causes terminal to terminal movement. The abrasion results in the formation of wear particles, which remain in the contact area. Those particles then oxidize, causing the electrical resistance to increase. Eventually, the connection will fail. Initially, the oxide layer builds up and interferes with the electrical conduction resulting in intermittent failure. As time passes, the failures increase until the condition is permanent.

The difficulty with failures from fretting is that after an initial failure, more vibration can move the contact points back into contact temporarily. Then, as time goes by, more corrosion builds up disrupting contact again. Cycles like these can occur until the corrosion permanently creates an open circuit.

Changes in temperature can also cause fretting corrosion. Differences in the expansion and contraction rates of metals can cause small amounts of terminal-to-terminal movement that creates fretting corrosion.

There are some basic steps to help minimize vibration



Vibration can cause connections to come apart and fail.

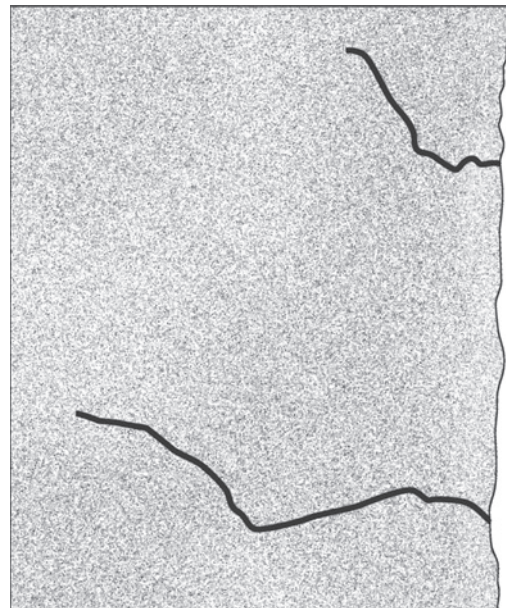

Under a microscope, cracked metal from vibration damage (fretting) is easy to see.



problems. For instance, make certain that all wires and connectors are secured appropriately. Always secure the wiring as it exits the connector. Cushioned clamps are an ideal means of mounting on high vibration locations. Where appropriate, add strain relief. Using dielectric lubricant helps prolong the life of terminal plating and delay the beginning of fretting.

### **Abrasion**

Vibration and road shock both cause wearing away of contact surfaces. Abrasion also occurs when wires are allowed to touch wear points such as frame members and other vehicle parts. Once the insulation is worn away, bare conductors may contact a ground source and create a grounded circuit. This can also lead to corrosion, raising the resistance in the circuit. Or it could cause wear to the point of fracture resulting in an open circuit.

Using the proper routing and coverings will help avoid wear areas and abrasion damage. Properly securing wires will also restrict unwanted movement. Keeping them in the proper location will help assure that wear is minimized or eliminated. There are other approaches to avoiding abrasion, too.

Worn coverings such as loom, convoluted tubing or spiral wrap should be replaced if they are no longer providing sufficient protection for the wires inside. Make certain that the replacement is the same size and the same material or better. Also, make certain that the covering is secured correctly. That's especially true in cases where there is the possibility of contact with moving parts such as lift gates, wheels or other equipment.

It's important to ensure that wires aren't exposed to sharp edges. Use grommets where they pass through and around metal parts. Check the insulation for signs of abrasion and replace wire if wear is detected. Always replace wire with the equivalent of the original or better. If the original wire isn't available, use a larger wire size as a replacement. For the same length of run and the same current, resistance will be greater in a smaller conductor.



Worn coverings such as loom, convoluted tubing or spiral wrap should be replaced if they are no longer providing sufficient protection for the wires inside.

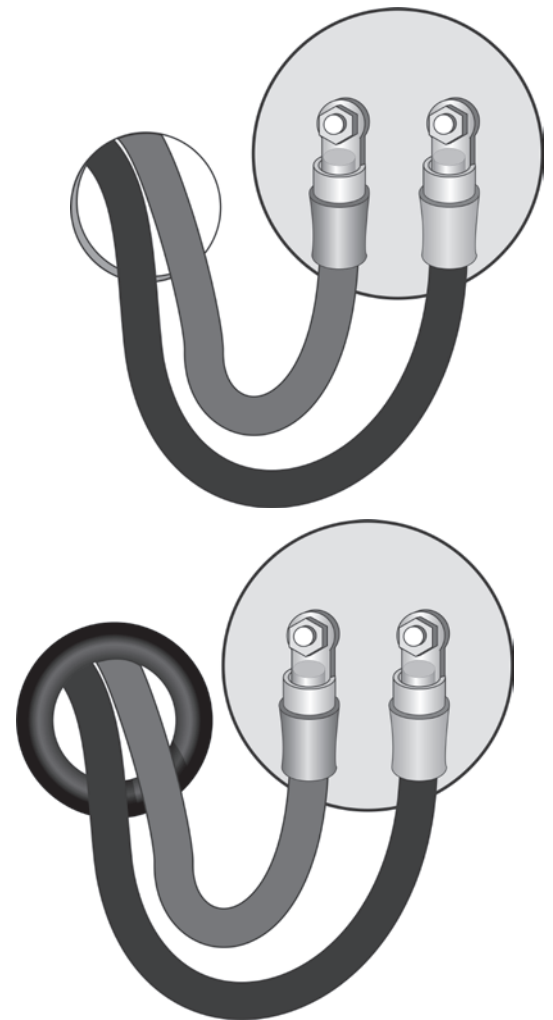

Use grommets where wires pass through and around metal parts.

### **Dust, Sand & Grit**

Accumulation of abrasive materials on wiring and lighting devices can not only be an annoyance, it can lead to damage, especially when combined with vibration. If gritty materials enter connections, it can accelerate the wear on contact points causing interruption of the circuit and failure of the devices. Sand and grit can also attract and hold moisture, creating conditions conducive to corrosion. In some cases, sand and grit may work their way inside protective coverings and abrade the insulation of wires running through it if there is relative motion between the covering and the wire.

One of the ways of reducing sand and grit buildup is to eliminate abrasive materials in the areas where wiring is present. Another way is to seal openings on protective coverings to keep gritty materials from entering. In addition, if there are unmated connectors in the system, they should be cleaned, dried and lubricated with a dielectric coating prior to connection to avoid abrasion problems.

### **Impact**

Wiring must be protected from the impact of rocks, gravel and other road debris. A major impact can cause enough damage to require extensive repairs. Smaller, more frequent impacts over time may deliver equally extensive damage. Damage from impacts can do damage although the wires are contained in a loom or other covering. During inspection, always check for damage from impacts and replace any wiring or devices that appear to be damaged. Make certain that the replacement parts are equivalent to or better than the original.

### **Chemical Exposure**

The materials used in the construction of a vehicle's lighting and wiring system are resistant for short-term exposure to most chemicals. But continuous exposure to many of the common chemicals found in and around trucks can cause plastics to swell, crack, soften or otherwise become degraded. Diesel fuel and hot engine oil are the main culprits.



In some cases, sand and grit may work their way inside protective coverings and abrade the insulation of wires.

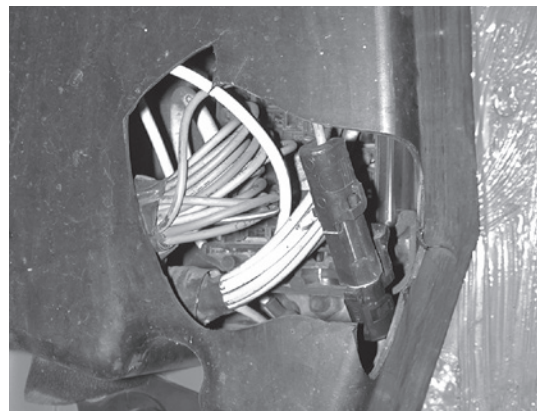

A rock thrown from a tire smashed this protective case exposing the wires and connections inside to the elements.

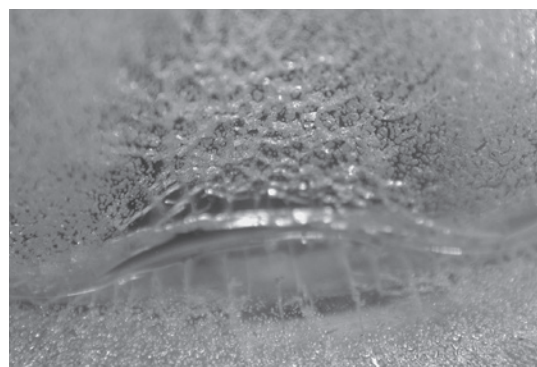

This close-up of the plastic lens on a marker lamp shows the effects of chemical damage.

To minimize the effects of chemicals, inspect the wiring for signs of degradation or damage. If it is occurring in an area that is generally free of contamination check for leaky hoses, gaskets or fittings and repair if damaged or leaking.

The best way to avoid damage from chemicals is to avoid them. Don't run wiring in areas where the chance for continuous exposure is likely, such as under fuel lines and filters.

**Temperature Extremes**

Vehicle applications require wiring components that have a wide range of temperature capabilities. For example, chassis wiring range should be from -40°C to +80°C. For high temperature operation, such as the engine compartment, the top of the range should be +125°C. In those environments, especially near engine and exhaust locations, it's necessary to use high temperature wires, heat shields or reflective coverings. Without those precautions, the wiring may melt, crack, char or even burn. Some materials, if exposed to high temperatures for a prolonged time become brittle. Where wiring might be exposed to high temperatures, try to protect it against flexing and impacts.

There are several steps to take when temperature extremes exist. Inspect the system and replace any broken, cracked, distorted or seriously discolored components. Re-route any wiring that's near a source of high heat. In situations where the routing must remain and the temperature exceeds 125°C, use materials that are suited to the environment including high temperature insulation and heat shield material.

**Choosing Wiring Material**

The most important factor in choosing wire, after selecting the gauge and choosing between solid core or multi-strand, is the temperature of the operating environment. Typically, 85° C (185° F) rated material may be used anywhere other than the engine compartment. 120° C (248° F) rated materials can be used anywhere including high heat areas. Wire insulation, tubing and connectors have different temperature ratings that should be considered carefully when making your selection. The accompanying chart shows the

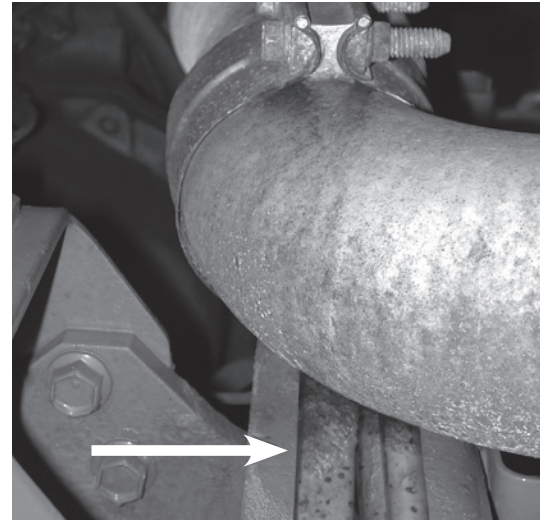

Wires routed past a hot exhaust pipe will be exposed to scorching hot temperatures that could cause damage.

<b>TEMPERATURE CHART</b>			
<b>Cable Size</b>	<i>Maximum Current Carrying Capacity (For 12 Volts at Listed Temperatures)</i>		
	120° F	125° F	150° F
20 Gauge	15 Amps	13 Amps	9 Amps
18 Gauge	18 Amps	15 Amps	11 Amps
16 Gauge	22 Amps	19 Amps	14 Amps
14 Gauge	27 Amps	23 Amps	17 Amps
12 Gauge	40 Amps	32 Amps	24 Amps
10 Gauge	50 Amps	42 Amps	31 Amps

**Note:** Currents above those listed may increase the temperatures of the PVC above a safe design level of 180° F.

Continuous Use Temperatures of Common Materials and Typical Applications							
Typical Continuous Use Temperature (°C/°F)		Conductor Insulation	Tape	Tubing	Connectors	Rubber Seals	Ties, Clips, etc.
Polyethylene	85 (185)		X	X			X
PVC	85 (185)	X	X	X	X		
Hi Temp PVC	105 (220)	X	X	X			
Polyamide*	120 (250)			X	X		X
Polypropylene*	120 (250)			X			X
X-link Polyolefin	130 (260)	X		X			
Polyester (PBT)*	165 (330)			X	X		
FEP	200 (390)	X		X			X
TFE	230 (500)	X		X			X
Silicone	230 (500)					X	
TPE*	85 (185) - 125 (260)	X				X	
*Note that there are a variety of materials having these descriptions and physical properties can vary significantly.							

continuous operating temperature ratings for many common materials.

**Tensile Loads**

Wiring should not be considered an appropriate load-bearing component. It’s easy to exceed the designed load limit by inadvertently installing wires under tension or snagging a section of wire on one of the moving parts. Using a wire bundle as a handhold or step can destroy the integrity of the conductor and connections. So can the weight of accumulated ice, snow, mud and other materials.

Too much stress on a wire may cause conductors to break, crimps to give way, and connections to pullout resulting in a system failure. Another problem arises when wires are pulled sharply to one side immediately after leaving a connector and are secured that way under tension. The stress may cause the connector’s seal to open on one side allowing moisture and contaminants to enter ultimately resulting in failure of the circuit.



Too much stress on a wire may cause conductors to break, crimps to give way, and connections to pullout resulting in failure.

To protect the integrity of the wiring, avoid tight bends in wires and bundles, especially near connector seals. Consider adding strain relief in areas subject to stress.

Never put stress on any wiring and connections. Support wires and bundles of wire approximately every 12 to 18 inches so that they are adequately supported and less likely to become snagged or pulled. Whenever possible, re-route wiring to avoid ice, snow and mud buildup.

### ***Flexing***

If wiring is installed where it will be subject to repeated flexing such as around doors, hatches and moving equipment, it is subject to special stress and wear. Copper strands will fatigue with repeated flexing. Tight radius bends add to the stress. Flexing increases the possibility of pinching and snagging. The extra length required in the lengthened position and positioning of the excess wire in the shortened position also present hazards.

Some basic steps if taken will help avoid problems where wires must be subject to repeated flexing. Avoid tight radius turns. Make sure that the wire is not snagged or stressed at its maximum extension. Also, make certain that the wire moves smoothly through its flexing cycle and doesn't rub or scrape adjacent components. When replacing wires in this situation, if special cables were used originally, be certain that the same or equivalent product is used as a replacement.

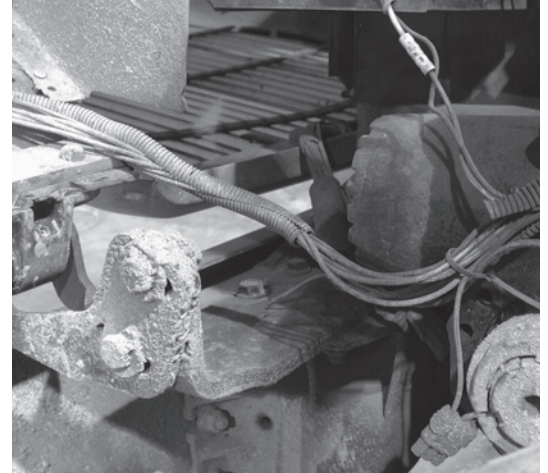

If wiring is installed where it will be subject to repeated flexing such as around doors, hatches and moving equipment, it is subject to special stress and wear.

## Section Two Quiz Questions

1. The most common effect of moisture on vehicle wiring and lighting is current diverted from it's designated ground. T/F **1. T**
2. "Wicking" means migration of moisture along trailer frame members. T/F **1. T**
3. Sealed connections are impervious to: **2. F**
  - a) Wind driven water
  - b) High pressure spray from pressure washers
  - c) Migration of water entering the wiring system from a cut or abrasion
  - d) None of the above
4. The best way to seal a connection against moisture is to use **3. d**
  - a) Plenty of electrical tape
  - b) A single layer of shrink tubing
  - c) A sealed system
  - d) None of the above
5. Protecting connections from high-pressure spray and road splash is easier using: **4. c**
  - a) Boots
  - b) Protective moldings
  - c) Convoluted tubing
  - d) All of the above
6. As long as a connector is not in use, it can be left open if kept isolated using electrical tape. T/F **5. d**
7. Drip loops refer to: **6. F**
  - a) A wiring accessory that prevents water from dripping on wires under a trailer Deck
  - b) A loop left in a length of wire that allows gravity to direct water away from electrical connections
  - c) A special connector with a small loop for securing the wires away from moisture
  - d) A type of loom
8. Rapid temperature changes can cause sealed systems to draw in water. T/F **7. b**  
**8. T**

9. Corrosion is commonly caused by:
- a) Moisture and dirt
  - b) The interaction of moisture and plastic
  - c) Moisture and salt
  - d) Electrical current flowing through plastic
10. Battery acid corrodes most metals found in a wiring system. T/F **9. c**
11. Corrosion shows up as a dark green oily substance. T/F **10. T**
12. Corrosion causes :
- a) Intermittent faults that cause lights to flicker
  - b) Short circuits
  - c) Increased resistance in the circuit
  - d) All of the above
13. Avoid corrosion build up by always: **12. d**
- a) Avoiding exposing wiring and lights to moisture and salt
  - b) Maintain protective boots, coverings and other protective devices in good working order
  - c) When possible, re-route wiring exposed to moisture and salts
  - d) All of the above
14. Contact between two dissimilar metals can cause a galvanic reaction leading to corrosion. T/F **13. d**
15. Dielectric coating reverses the action of moisture and salt. T/F **14. T**
16. \_\_\_\_\_ or terminal to terminal movement leaves wear particles **15. F**  
which can oxidize and cause greater resistance and eventually connection failure.
- a) Powdering
  - b) Fretting
  - c) Slivering
  - d) Granulating
17. With certain types of vibration-caused corrosion, an oxidized layer can cause intermittent failure. T/F **16. b**
- 17. T**

18. Among the ways of minimizing vibration's effects are:
- a) Using clamps to stop unnecessary movement
  - b) Securing wire as it exits a connector
  - c) Use of dielectric coating to help avoid contact wear
  - d) All of the above
19. Abrasion can be minimized by properly securing wires, keeping them away from sharp components and using loom, convoluted tubing and other protective devices. T/F **18. d**
20. Sand and grit aren't serious problems for electrical systems because, unlike corrosion, they seldom react with moisture. T/F **19. T**
21. Impact damage is always apparent to visual inspection. T/F **20. F**
22. Typically, exposure to chemicals will not harm wiring system components if limited to a short time. T/F **21. F**
23. Diesel fuel is not considered a chemical. T/F **22. T**
24. The best way to avoid the effects of chemicals on wiring systems is to : **23. F**
- a) Check for damage regularly
  - b) Change chemicals to a less damaging type
  - c) Route wiring away from the source of exposure
  - d) All of the above
25. The normal service temperature range for vehicle electrical components is -40°C to +80°C with the top range at +125°C for under hood environments. T/F **24. c**
26. Wire left exposed to elevated temperatures will not burn even though it may melt and crack. T/F **25. T**
27. Where elevated temperatures have caused damage, repairs should include inspecting the system and: **26. F**
- a) Replacing any broken, cracked or distorted parts
  - b) Replacing any seriously discolored components
  - c) Rerouting to avoid high temperatures
  - d) All of the above
28. Trailer wiring should never be used as a step or to support a load. T/F **27. d**
- 28. T**



29. Wire pulled sharply to one side after leaving a connector may:

- a) Cause the connector's seal to open
- b) Lower the resistance of the connection
- c) Improve the seal
- d) Eliminate all possibility of corrosion

30. Which of the following doesn't help to avoid stress on wires:

**29. a**

- a) Support wires every 12 to 18 inches
- b) Re-route wires to avoid snags and pulling
- c) Do not use wires as hand holds or foot holds
- d) Replace with heavier wire

31. Repeatedly flexing copper strands will strengthen them. T/F

**30. d**

**31. F**

## **Section Three**

### **Mastery Statement**

When you have successfully completed this section, you will have mastered the following:

- Wire control and protective products.
- How to use heat-shrink butt connectors and solder-link connectors.
- How to use wire control and protection products.
- The installation and routing checklist.

## Wiring Protection

*Since the performance of vehicle wiring can be compromised by a wide variety of causes, it's vital that precautions be taken against as many of these circumstances as is practical. Some of these basics are included in the following section.*

### **Wire Control & Protection**

#### **Tape**

Tape should not generally be used alone for securing wire bundles, especially PVC plastic (polyvinylchloride), “electrical” tape. This should only be used to hold bundles of wires together within coverings such as looms and convoluted tubing. Some specialty tapes (such as glass fiber tapes) may be used where increased resistance to heat and chemicals are required. When using tape on the wiring of a truck, check the manufacturer’s specifications for information on when to use.

#### **Heat Shrink Tubing**

A good way to protect wiring installations is to use heat shrink tubing. Heat shrink tubing contracts under application of heat by a ratio of as much as four to one. It is designed to cover and seal connections against moisture, dust, grit, chemicals, corrosive materials and abrasion.

Heat shrink tubing is available in PVC, polyolefin, silicone and fluoropolymers. It comes in single wall or a dual wall version, which contains a layer of encapsulant that flows under heat to fill irregularities.

Some dual wall comes with a special hot melt adhesive. This stands up to underhood temperatures as it forms a barrier against engine fluids, moisture, contaminants, corrosives and water wicking.

On a typical splice, a 2”-3” section of tubing is placed on the area to be covered. Heat is applied at the center until the tubing has contracted around the splice. Then the heat source is moved left and right until the entire section of tubing is snugly fitted around the wires.

Dual wall tubing is used to seal areas that are likely



Standard electrical tape doesn't hold up well under road conditions. It has a tendency to lose its grip and come loose.

to be exposed to significant amounts of moisture or road splash. It can also serve as a strain relief where a wire joins a bundle.

### **Heat-Shrinkable Connectors**

Even for simple splice connections, it's important to make the splice as water-tight as possible. To facilitate this, products are available that will make your job easier. Heat-shrinkable connectors protect splices from moisture while providing strain relief for the connection. They also protect against vibration, while completely insulating and protecting the electrical connection. Grote makes a heat-shrinkable connector that has an adhesive lining to provide more reliable protection than conventional splices.

A high-quality heat-shrinkable connector also provides resistance to most vehicle related solvents including diesel fuel, antifreeze and brake fluid.

### **Heat Shrinkable Solder-Splice Connectors**

For the ultimate splice connection, Grote makes a heat-shrinkable connector that already contains the right amount of solder for a perfect splice. They're not only easy-to-use, but the integral solder helps to ensure that your splice won't come apart from vibration. The solder melts at 145° C (293° F). Maximum operating temperature for these connectors is 125° C (257° F). Solder-splice connectors are UL and CL recognized.

### **Other Tubing Products**

Another way to organize and protect wiring is with convoluted tubing. This product is designed to protect wires from detrimental environmental factors, while offering easy access to them. The material used is typically PVC, polypropylene, polyamide or other materials designed for special environments (such as extreme heat conditions).

This tubing is typically available from 1/2" to 2" in diameter and in slit and non-slit varieties. The slit version makes installation and later service easy and efficiently. The slit variety should be secured approximately every 12 inches to keep the tubing closed and the wires contained.

Wiring should be secured wherever it exits the tubing to guard against abrasion from the edge of the tubing. The



Heat shrinkable butt connector.



Products such as convoluted tubing will protect and neatly organize bundles of wire.

size tubing selected should allow the enclosed wire to fill approximately 80 % of its diameter.

Another product for controlling and protecting wiring is fiber loom. It protects against moisture with an asphalt compound and is non-metallic. Plastic loom is also available.

Spiral wrap allows easy lead out of wires because of the construction, which leaves a continuous slot the length of the tube. It has a built-in memory that allows it to stretch to accommodate a wire, then to regain its original size.

### **Boots/Covers**

An alternate approach to protection is to use specially made rubber or plastic coverings ... also referred to as boots. They are designed for attachment to the back of connectors, protecting them from water splash while offering a degree of strain relief.

### **Wire Support**

An important factor in both installation and repair of wiring systems is to provide a series of secure attachment points along the installation route that keep wires in their proper locations. Proper support also helps protect them from vibration as well as keeping them out of the way of road debris that may be thrown up.

Secured wiring is less prone to snagging, tensile loading from snow and ice and contact with moving parts. Support points should be located every 12" to 18".

One of the most popular means of support is a clamp. Clamps come in a range of styles and sizes from 1/2" to 2" in diameter, and are made from lightweight nylon that is very resistant to corrosion and rust. However, nylon clamps may prove to be less durable than metal, especially where there are a large number of wires to be secured together. They are well suited for locations such as truck cabs and certain chassis areas.

For optimal performance of plastic clamps, the weight of the wire bundle must be reasonably low, the potential for impact, vibration and road shock moderate, and the heat environment less than 100°C. Some plastics may turn brittle with constant exposure to high temperatures.

Metal clamps resemble the nylon variety in shape and

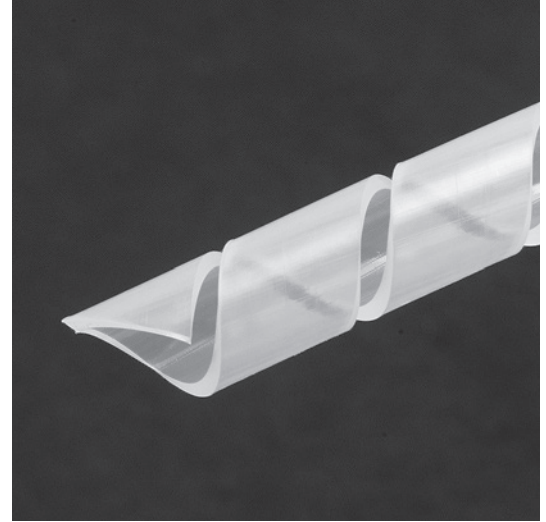

Spiral Wrap

also come in a similar variety of sizes. Some varieties of metal clamps are coated with a layer of neoprene rubber that cushions the wires from contact with the edges of the clamp body. This rubber coating also provides a layer of insulation and resists corrosion.

Wire ties are another approach to securing wires. They are used over short routes when the number of wires is modest and the bundle is supported by the mounting surface.

Ties come in a variety of sizes and types ranging from miniature to heavy duty and from black and white to colors (making it easy to color code bundles). A particularly useful type is the “Mounting Tie”, which has a hole drilled in the body of the tie to allow a screw to secure the bundle in place on a chassis component.

Acceptable fasteners include rivets or correctly sized threaded fasteners, such as screws and bolts. Certain types of plastic fasteners such as Christmas tree barbed styles and snap-in studs are also acceptable. Plastics are used in cabs and in certain chassis areas.

### **AN INSTALLATION & ROUTING CHECKLIST**

There are certain factors that should be considered virtually every time an installation or repair is done. The installation process should be done in such a way as to minimize the possible harmful effects to the wiring components and the vehicle itself.

### **GENERAL FACTORS:**

- Avoid unfavorable environmental factors on connectors such as water spray, continuous chemical exposure or unprotected exposure to moving parts.
- Use effective mounting methods to minimize wire movement and to ensure that wiring remains in place and secure.
- Use a good covering system such as convoluted tubing as your first line of defense against harsh environments.
- Consider what additional protection might be required (such as heat shielding or the use of high temperature wire and cable) where wires must be routed through high heat environments.



Wire clamps (above) come in a variety of materials and are important for securing wires.

### **CONDITIONS TO AVOID**

- Always attempt to route wiring out of the range of impact from rocks and road debris.
- Check the routing to make certain wires will not be contacting any moving parts.
- Avoid situations where wiring is in contact with sharp edges or abrasive surfaces.
- Secure wiring carefully to avoid the effects of vibration and road shock.
- Make certain that wires are routed to avoid buildup of ice, snow or mud that might add stress to the wire.
- Avoid tight radius bends, which add stress to wires and cause the connector seals to open.



Avoid situations where wiring is in contact with sharp edges or abrasive surfaces.

### **SPECIAL PRECAUTIONS FOR AVOIDING WATER PROBLEMS**

- Whenever possible, use sealed connector systems.
- Make certain that every seal is in working condition.
- Seal all exposed copper crimps and splices with dual wall heat shrink tubing.
- Route wires away from areas subject to high-pressure washer application.
- Whenever possible, protect connections with covers, boots, heat shrink shields or other protective devices.
- Don't allow connectors to be located in standing water nor allow water to pool on connections.
- Avoid locating wires and connections in areas subject to road splash and high water levels
- Where possible, create drip loops and direct water away from connections
- Use dielectric lubricant in sealed connectors carefully. Do not apply too much, as this can force open the seal and expose the connectors to water and contaminants.

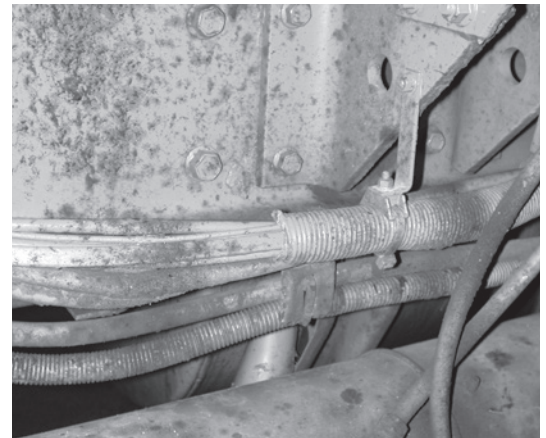

Secure wiring carefully to avoid the effects of vibration and road shock. This wiring has to live in a rough environment, but it's well secured.

### **AVOID PROBLEMS WITH FLEXING**

- Avoid stressing wire in the lengthened position.
- Ensure that the wiring will not rub or otherwise contact adjacent components in its shortened, finally installed position.
- The wiring must move smoothly through the flexing cycle and not be subject to pinching or snagging.
- Avoid small radius turns or kinks.

## Section Three Quiz Questions

1. Tape, especially electrical tape, is the correct product to use for securing wire bundles. T/F
2. Heat shrink tubing shrinks as much as: **1. F**
  - a) 2 to 1
  - b) 6 to 1
  - c) 4 to 1
  - d) 5 to 1
3. Heat shrink tubing is used to protect connections from: **2. c**
  - a) Moisture and corrosion
  - b) Stress
  - c) Abrasion
  - d) All of the above
4. When applying heat to a piece of shrink tube always start at the center to ensure that all moisture is forced out of the connection, working your way out to insure a proper seal. T/F **3. d**
5. Dual-wall tubing is used in those areas that are unlikely to be subjected to moisture and corrosion. T/F **4. T**
6. Hot melt adhesive-style shrink tubing should be used where under hood temperatures are high and you need to form a barrier against corrosives, chemicals and moisture. T/F **5. F**
7. Convuluted tubing offers: **6. T**
  - a) A way to organize wires
  - b) Protection from the environment
  - c) Ease of access
  - d) All of the above
8. Convuluted tubing is available in polypropylene, polyamide, PVC and cotton. T/F **7. d**

**8. F**



9. Tubing size should be selected so that the wire fills it to approximately \_\_\_\_\_ of its diameter:
- a) 50%
  - b) 100%
  - c) 25%
  - d) 80%
10. Which of the following is not recommended for controlling and protecting wires and bundles? **9. d**
- a) Fibre loom
  - b) Spiral wrap
  - c) Plastic loom
  - d) PVC tape
11. Which of the following is not typically a benefit of securing wire along the designated path: **10. d**
- a) Protection from rocks and debris
  - b) Protection from ice and snow
  - c) Some wires can be eliminated
  - d) Protection from vibration
12. The drawback to using nylon clamps is that they are prone to rust and corrosion. T/F **11. c**
13. The highest operating temperature for nylon clamps is: **12. F**
- a) 50° C
  - b) 80° C
  - c) 32° C
  - d) 100° C
14. Some metal clamps are coated with neoprene rubber. T/F **13. d**
15. The term “mounting tie” refers to one that has an adhesive to affix it to a body or frame component. T/F **14. T**
16. Support points for wire bundles should be spread: **15. F**
- a) From 6 inches to 12 inches
  - b) From 2 feet to 3 feet
  - c) From 12 inches to 18 inches
  - d) From 18 inches to 24 inches

**16. c**

## **Section Four**

### **Mastery Statement**

When you have successfully completed this section, you will have mastered how to handle:

- Total system failure.
- Single lamp outage.
- Replacing wire and cable.
- Correcting voltage problems.
- Improper grounding.
- Using proper lamps.
- Cleaning lenses.
- Proper lamp mounting.
- Eight major factors in lighting failure.

## System Troubleshooting

*This section outlines procedures that have been proven over time to be efficient and accurate in diagnosing problems in the lighting and wiring systems. In addition, there are also tips on remedying problems and avoiding trouble in the future.*

There is a wide variety of problems that can cause vehicle lighting and wiring systems to fail. Following are two systematic approaches to troubleshooting lighting problems.

### **Total System Failure**

If a trailer has a total system failure (no part of the system appears to be energized), the following are basic steps in diagnosing the problem:

- Check to make certain that there is electrical power going to the nose of the trailer;
- Check that there is a good ground;
- Check the nose receptacle for general condition, that the connections are secure and that there is electrical power present;
- Check the main harness for signs of damage or failure;
- Check the main harness at the rear sill connection;
- Check rear sill connection with lamps.

### **Single Lamp Outage**

If the trouble appears to be isolated to one lamp or lighting device:

- Check the lamp in question with a lamp tester. If the lamp functions, reinstall it;
- With power on, check the pigtail for continuity using the tester. If the pigtail functions, check the jumper that connects the pigtail to the sill harness or the main harness.

### **Assuring Good Connections**

When working on wiring and the harnesses, jumpers, pigtails and other connectors must be disconnected. Care should be taken to keep them dry and free of contamination. During reassembly, completely clean the components and carefully coat the connectors with Grote Corrosion

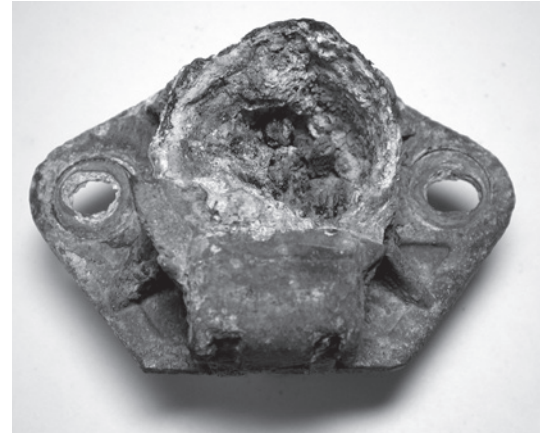

Believe it or not, this is a 7-way trailer connector. It has been so badly eaten away by corrosion that only one or two of the lugs are still visible. The result of this kind of corrosion will always be total system failure.

Preventive Sealant to prevent moisture and other contaminants from entering.

NOTE: Avoid using sodium-based anti-corrosion coatings or greases. Sodium will emulsify (turn soapy) and dissolve if it is exposed to moisture. Sodium will also increase the chance of corrosion.

Some other practices will also help to assure good connections. For example, take care to fashion secure junctions even when making temporary splices. Use a heat shrinkable butt connector which adds strength to the joint and helps exclude moisture and contaminants.

If soldering a connection, use resin core solder only. Never use acid core solder, since it can cause corrosion. As with other types of connectors, always use shrink tubing to protect the solder joint.

Do not use electrical tape alone to secure and seal connections. Over a relatively short period of time, tape will relax and allow moisture and corrosion to enter (and will hold contaminants as it relaxes, accelerating the rate of damage).

### **Take Care When Using Testers**

It's tempting to peel away a section of the insulation on a wire or use the sharp end of a tester probe to penetrate the plastic coating in order to reach the copper wire inside.

Although this approach may be the fastest way to test a specific circuit, the damage done to the integrity of the insulation can create many problems in the future.

For example, moisture and corrosives entering the wire at the cut or puncture can “wick” or travel inside the insulation and reach connection.

Over time, that buildup of contaminants is enough to eat into other components and cause the connections to fail. Once started, the wicking action can run throughout the entire wiring system and potentially corrode every connection in the system.

The correct testing method is to utilize termination points along the main and rear sill harnesses, jumpers, pigtailed and other wiring devices, as well as the lamps themselves. This approach will provide timely results and protect the wiring from additional damage.



Do not use electrical tape alone to secure and seal connections.

### ***Replacing Wire & Cable***

One of the most important things to bear in mind is that replacement wire should be equal to or heavier than the original equipment. Using lighter gauge wire without reducing the current draw could result in damaging heat due to the higher resistance. Another result may be diminished light output, as the current is “choked” because of the reduced capacity of the wire.

It is essential to avoid the use of splices whenever possible. Splices naturally become weak spots in the wiring system. Even the best of them can pull apart and offer another potential opening for moisture and corrosion. As indicated above, necessary splices should be reinforced and sealed with the appropriate heat shrink tubing as a precaution. Be careful to use the proper sized crimping tool to ensure that the crimp is sound and secure.

Other components in the system should be discarded and replaced when damaged or worn. Replace lamp assemblies, pigtails, jumpers or other components that malfunction and could contaminate other parts of the system.

### ***Correcting Voltage Problems***

“Under-voltage” has a number of causes. Poor connections are the major cause of under-voltage. Undersized replacement wire can be the culprit in some cases. Any under voltage or dim light problem should be tracked down and solved before it progresses to a complete system failure. Diagnose the underlying problem, don’t simply raise the voltage and consider the problem solved.

The same is true of over-voltage, which can damage electrical system components. For example, operating an incandescent lamp at as little as five percent over design voltage reduces the life of the lamp by 44%. Operating at 10% over can reduce lamp life by as much as 68%.

A good clue that the electrical system is being subjected to over-voltage is a pattern of repeated lamp failures with “no cause.” That is especially true when the failures involve headlamps and dash lighting.

Ideally, system voltage should be adjusted to meet minimum acceptable levels for proper operation. In practical terms, that would suggest that the ideal voltage going into



Avoid the use of splices whenever possible.

the nose of the trailer should be 12.5 volts, a recommended TMC procedure.

### ***Improper Grounding***

A proper ground is required in order for the system to operate. Even with the appropriate voltage supplied to a lamp, for example, without a proper ground, the lamp will not operate. A loose or disconnected ground wire is often the cause of lamp failure when harnesses and other components are in perfect condition and power supplied to the lamp is at the optimum level. That's especially true where a chassis ground is used.

Always check to make certain that the ground connections are secure and clean. When lamps are grounded through the lamp housing, make certain that there is a tight, metal-to-metal connection that is clean and not corroded. If a lamp is grounded with a separate ground wire to the chassis, use a ring terminal instead of a spade or hook terminal to protect against accidental disconnection.

### ***The Proper Lamp For Each Location***

It's very important to make certain when replacing lamps that a comparable lamp is used. Replacing dome lamps with backup lamps, for instance, is a common but dangerous practice. Backup lamps usually have high candlepower bulbs that generates high temperatures. Under certain conditions, this excessive heat can cause interior fires that can destroy wiring, lighting devices or the entire vehicle.

Replacing a license lamp with a utility lamp is not allowed, since it doesn't meet FMVSS 108 requirements.

### ***Heat's Effect On Lamps***

Typically, lamps will last longer if they run cooler. Elevated temperatures represent some of the most damaging operating conditions, especially for incandescent lamps.

The most common cause of heat related failures is lack of air movement. Leaving lamps on when the truck is parked against a dock, especially in hot weather, can severely limit service life by causing the temperature in and around the lights to jump. Melted lenses are a sign that the vehicle has been left with the lights on while up against the dock.



Since dirt and corrosion are ever-present enemies, care should be taken to make sure that a proper ground is securely made.

Another cause of increased operating temperatures is dirty lenses. A buildup of mud and grime adds a layer of “insulation” to the lens creating higher temperatures inside. Cleaning the lenses also improves overall safety by making the vehicle easier to be seen.

### **Cleaning Lenses**

Care should be taken to choose only cleaning agents that are compatible with the lens and housing material, especially polycarbonate parts. Polycarbonate is 50 times stronger than acrylic, but doesn’t stand up to chemicals and solvents well.

Although the parts are tough and resist wear and impact breakage, use of cleaning agents that are not compatible may cause softening, crazing, or cracking. This is particularly true in situations where lenses and mounting bases are mounted on an uneven surface. If a lens or housing appears to be partially melted, it’s possible that solvents have attacked it. This type of damage will also show up as a surface that feels rough to the touch.

The chart below shows a selection of cleaning agents that are compatible with polycarbonate (and a group of agents which are not). If a cleaner is not represented as acceptable on the chart, do not use it. Choose one of those shown as compatible.

See tables at right.

### **Proper Lamp Mounting**

An overall guideline is to avoid over-tightening mounting screws. Tighten until screws are snug. A marker lamp will typically be tightened in the 8 to 20 inch lbs. range. Avoid any more than 20 or there is risk of distortion, cracking, breaking or causing the lens to pop off.

Always check to make certain that the pigtail or jumper is not positioned so that it prevents the housing from seating properly and mounting flush with the surface. Improperly mounted lighting devices will have a shorter service life because mis-mounting will allow water and other contaminants to enter the housing from behind.

#### **SOLVENTS/CLEANERS COMPATIBLE WITH POLYCARBONATE**

Mild soap and water
Mineral Spirits
Mexane
VM and P Naphtha
Varsol No. 2
#1 & #3 denatured alcohol
Freone TF and TE-35
Ethanol
10% Sol Bon Ami
Dirtex
2% Sol. Reg. Joy
Heptane
White Kerosene
Methyl, isopropyl and isobutyl alcohols
Lacryl PCL-2035 polycarbonate cleaner
Petroleum Ether/65° C boiling point

#### **SOLVENTS/CLEANERS NOT TO BE USED WITH POLYCARBONATE**

Trichlor
Acetone
Triclene
Methyl Ethyl Keytone (MEK)
MIBK
Toluol
Benzol
Gasoline
Carbon Tetrachloride
Chlorinated Hydrocarbons
Texize-8006, 8129, 8758
Liquid Cleaner-8211
Agitene
Ajax
All Liquid Detergents
Pink Lux (Phosphate free)
Kleenol Plastics
Lemon Joy (Phosphate free)
Diversol
Lestoil
Lysol
Stanisol Naphtha
Oils

Devices marked with “TOP,” should always be mounted with that designation up when installing the unit. Failure to do so will result in the shock mount being installed with the wrong orientation. The result can be as much as 25% shorter lamp life. In addition, the mis-oriented lamp may fail to provide the correct light pattern and will lack the designed visibility.



Avoid overtightening screws protect against distortion, cracking, breaking or causing the lens to pop off.



## Section Four Quiz Questions

1. What three general areas should be checked if there is a total trailer system failure indicated?
  - a) Nose box, main harness and rear sill
  - b) Sill, nose box and coolant
  - c) Lamps, main harness and all fluid filters
  - d) None of the above
  
2. If just one lamp is not working, the best approach is to replace it and move on. T/F **1. a**
  
3. Sodium based anti-corrosion coatings are superior to other types because they emulsify when exposed to moisture. T/F **2. F**
  
4. For electrical work, the best solder is: **3. F**
  - a) Resin core
  - b) Acid core
  - c) PVC core
  - c) None of the above
  
5. Electrical tape: **4. a**
  - a) Relaxes and lets contaminates in to the connection or splice.
  - b) Tightens with age to make a rigid joint.
  - c) Stays about the same.
  - d) Is the appropriate choice for masking off areas that need to be painted.
  
6. Wicking takes place when water travels along the outside of a wire's insulation. T/F **5. a**
  
7. Increasing the current level in a circuit means: **6. F**
  - a) You can get by with a thinner wire
  - b) The lamps will be brighter
  - c) Wire is likely to run hotter
  - d) All of the above
  
8. Using splices in a circuit is preferable to single piece of wire because it's easier to isolate a problem on that circuit. T/F **7. d**
  
9. It's very important to make certain when replacing lamps that a comparable lamp is used. T/F **8. F**

---

**9. T**

10. With dim lights, the approach is to adjust the voltage upward until the lights appear normal during the daylight hours. T/F **10. F**
11. At 5% above design voltage, the lamp life is shortened by approximately: **10. F**
- a) 44 %
  - b) 12 %
  - c) 66 %
  - d) 30 %
12. Normal voltage at the nose of the trailer should be: **11. a**
- a) 22.5 volts
  - b) 12.5 volts
  - c) 13.6 volts
  - d) 11.5 volts
13. In order to operate correctly lamps must have a ground even though the correct voltage is supplied. T/F **12. b**
14. A chassis ground uses \_\_\_\_\_ as a ground: **13. T**
- a) The battery
  - b) Connection to the vehicle structure
  - c) The light switch
  - d) All of the above
15. Corrosion at the ground connection helps make the connection more efficient. T/F **14. b**
16. Polycarbonate parts are impervious to cleaning products. T/F **15. F**
17. Replacing a dome lamp with a backup lamp can be dangerous because of the high heat out put of the backup lamp. T/F **16. F**
18. Lamps will last longer if they: **17. T**
- a) Run cooler
  - b) Run hotter
  - c) The trailer has been operating in winter conditions
  - d) All of the above
- 18. a**

19. Melted lenses are a sign that:
- a) The trailer has been parked in the sun
  - b) The lights were left on with the trailer against the dock
  - c) There was a fire in the trailer
  - d) None of the above
20. A buildup of mud and dust adds “insulation” to the front of a lamp raising the temperature. T/F **19. b**
21. To avoid over tightening the screws when installing a new lamp, tighten them to: **20. T**
- a) 40 inch pounds
  - b) 10 inch pounds
  - c) 33 inch pounds
  - d) 50 inch pounds
22. Failure to mount a lamp marked with the word “Top” with the correct orientation can result in as much as 25% shorter lamp life. T/F **21. b**
- 22. T**

## **Section Five**

### **Mastery Statement**

When you have successfully completed this section, you will have mastered the following:

- What the three basic wiring harness problems are
- Open circuits
- Short circuits
- Grounded circuits
- How to trouble shoot the three problems

# Troubleshooting Trailer Wiring Harness Systems

*Whether caused by rust and corrosion or other problems, most wiring harness problems fall into one of three categories. This chapter will help you to identify and troubleshoot each one of them.*

## **Before Starting The Diagnosis**

When it's necessary to disconnect the harness or other connections during troubleshooting, use this opportunity to thoroughly clean the terminal components and apply a good quality dielectric coating before reconnecting.

If a lamp is removed for testing and will be reinstalled, clean the terminals to remove any oxidation, corrosion or other residue. Then add a dielectric coating to both the lamp and socket and replace the lamp. When in place, test the lamp one final time for proper operation.

Always check the 7-way power cable. Verify that the circuits are all functioning at their design capacity. If there is no power, check the integrity of the power from the tractor. This step must not be skipped because from this point on, proper power to the trailer must be available.

Any reference in this section to “repairs” refers to temporary, emergency repairs only. Given the typical operating environment, the components that are repaired should be replaced as soon as possible. That will maintain the integrity and reliability of the wiring harness and minimize failures and additional repairs in the future.

Also, remember that the term “ground” refers to both the chassis ground and a ground return wire. The chassis ground is typically a frame rail or other conductor. In all cases, each possible ground must be tested.

## **The Three Basic Wiring Harness Problems**

The wiring harness is subject to three basic problems, any of which can cause lamp failure. They are:

- Open Circuits
- Short Circuits
- Grounded Circuits

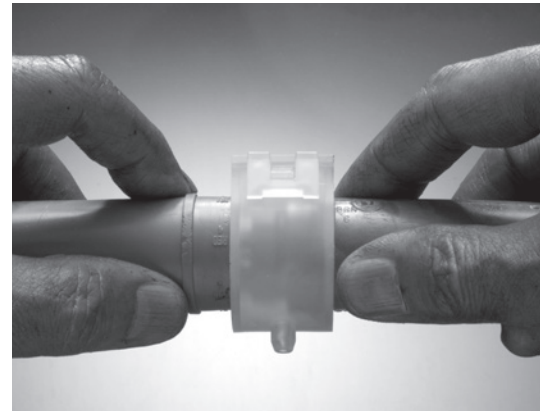

Always check the 7-way power cable.

### **Open Circuits**

An open circuit refers to an interruption in the circuit, such as a break in the wire. However, it could refer to an unplugged connector or a terminal that has come loose from a chassis ground connection.

With an open circuit, current is prevented from flowing to all areas of the circuit. This means only the portion of the circuit between the break and the grounding point is affected. Lamps connected before the break will still function. The break can be in either the power or the ground segment of the circuit.

*Suspect an open circuit if the circuit breaker is good and some of the lamps on that circuit are not operating.*

### **Short Circuit**

A short circuit occurs when conductors from two different circuits make contact.

*Suspect a short circuit when lamps are operating intermediately with those on another circuit ... for instance, clearance marker lamps are operating with stop lamps when the brakes are applied.*

The most common cause of a short circuit is that two conductors are allowed to rub against each other until the insulation wears away. Wires that are not secured are among the most likely candidates, especially where there is significant vibration present.

### **Grounded Circuit**

A grounded circuit takes place when the power circuit conductor comes in contact with a ground source, typically the vehicle chassis (like the frame rails of a trailer). If an unsecured wire or bundle is allowed to contact a sharp edge on the metal frame member, the insulation is cut or damaged due to the vibration. With the insulation gone and the bare conductor exposed, the frame can act as a ground source.

*Suspect a grounded circuit if the circuit breaker cycles and there is no load on the circuit.*

### **Troubleshooting An Open Circuit**

It's reported that more than 90% of the open circuit conditions reported can be traced back to failed lamps. When



Open Circuit



Short Circuit

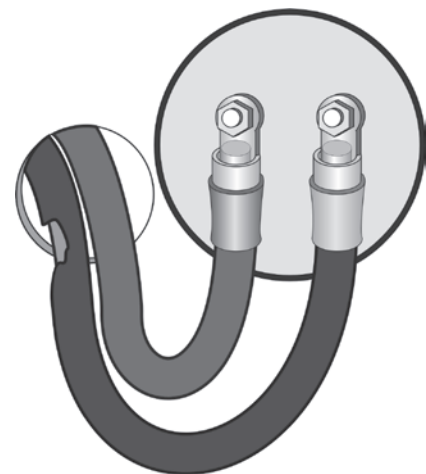

Grounded Circuit

troubleshooting, always test the lamp or lamps in question carefully. Remove the lamp; clean the contacts and retest. If the lamp still fails, replace it. If it works, apply a good quality dielectric coating, like Grote's corrosive preventative sealant 99170, to the contacts and continue testing for other causes.

Continue testing from the front of the trailer. When the need arises to disconnect components, always follow the procedures outlined above to clean and protect the connections with dielectric coating to protect against future failures.

### **OPEN CIRCUIT TEST 1**

Disconnect the main harness from the 7-way receptacle and use a continuity tester to check the circuit in the receptacle.

If the tester doesn't light up, the indication is that it is an open circuit. In this case, the 7-way receptacle appears to be the problem. Replace it with an equivalent unit.

If the tester lamp lights up, there is power to this point and further testing is required.

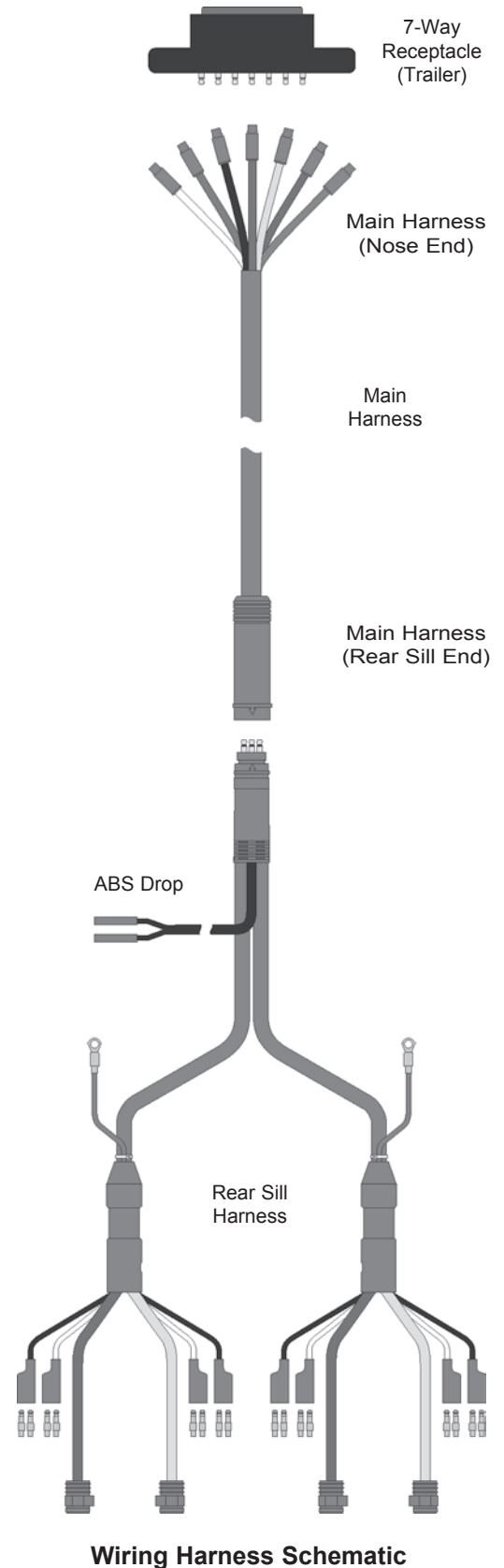
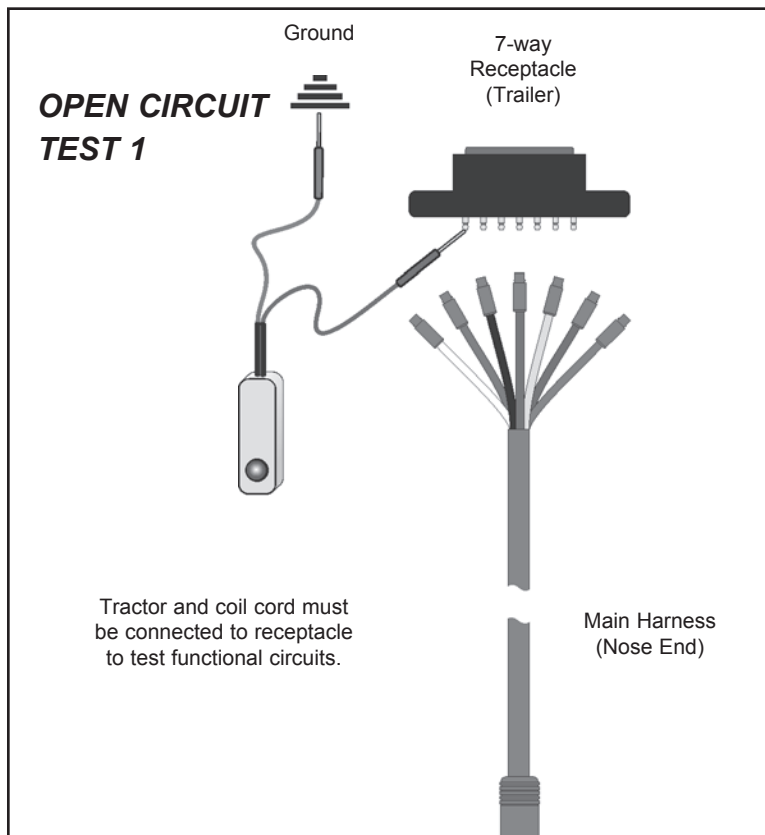

### **OPEN CIRCUIT TEST 2**

Reconnect main harness to the 7-way receptacle and disconnect the rear sill harness from the main harness. Use a tester and check the circuit between the main harness and the ground.

If the tester does not light, you have found the open circuit. The problem is in the main harness. Repair or replace the main harness. If the tester lights up and stays on, you have power to this point. Further testing is required.

### **OPEN CIRCUIT TEST 3**

Reconnect the rear harness to the main harness and disconnect the jumper (and/or pigtail) wire in question. Using a tester, check between the circuit in question on the rear sill harness and the ground.

If the tester does not light, you have found the open circuit. The problem is in the rear sill harness. Replace or repair the rear sill harness. If the lamp lights up and stays on, you have power to this point. Further testing is required.

### **OPEN CIRCUIT TEST 4**

Reconnect the jumper wire to the rear sill harness and disconnect the lamp. Using a tester, check between the circuit in question on the jumper wire and the ground.

If the tester does not light, you have found the open circuit. Replace the jumper wire.

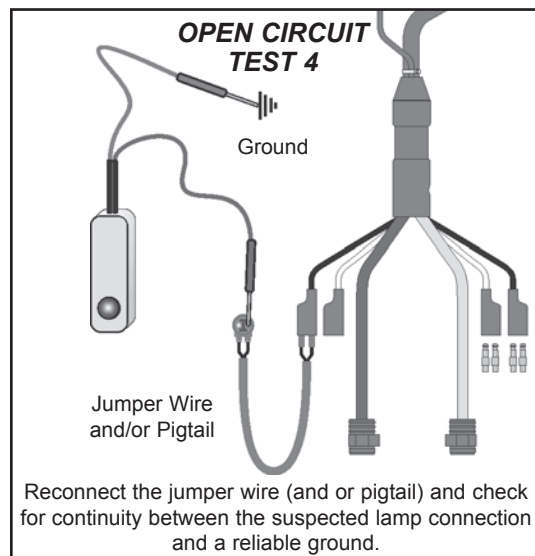
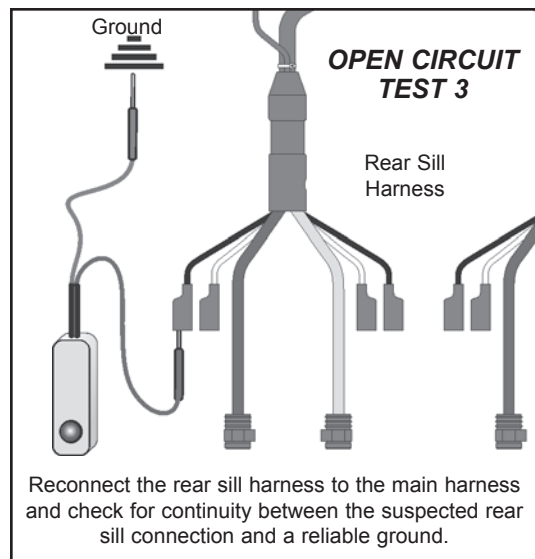
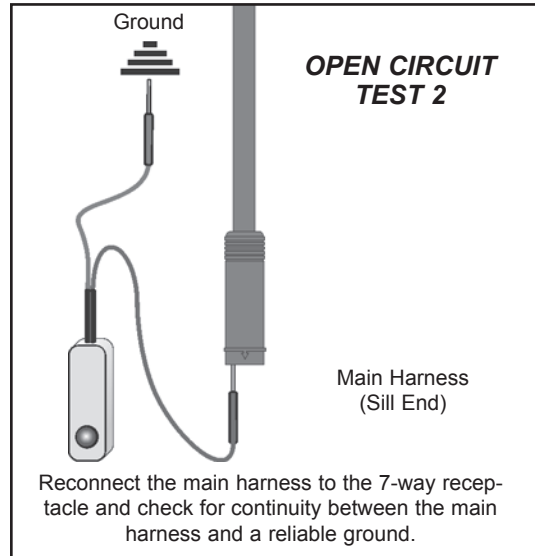

**Note: All Grote Rear Sills have redundant grounds hooked through the main and ring terminals. Disconnect the ring terminal (chassis ground) when testing.**



### **Trouble Shooting A Short Circuit**

When the lamps are lighted in a circuit that should be off, it's likely that there is a short circuit. Of the three failures discussed here, this is the most difficult problem to find. Fortunately, it is the least common of all problems.

Do all of the testing on the malfunctioning circuit. First, visually inspect for the problem. If it's not obvious, then start the following tests from the rear of the trailer. When disconnection is required, follow the proper procedures for cleaning and using dielectric coating before reconnecting.

#### **SHORT CIRCUIT TEST 1**

Do not remove the lamps in question. Turn off all power with the exception of the malfunctioning circuit. Disconnect the jumper wire from the rear sill harness. Using the tester, check between the rear sill harness and ground.

If the tester does not light up, the problem is in the jumper wire. Locate and repair the short. Look for two bare wires or terminals crossed. This may require replacing the jumper wire. Reconnect the circuit. If the tester lights up, the shorted circuit is not in the jumper wire and further testing is required.

#### **SHORT CIRCUIT TEST 2**

Disconnect the rear sill harness from the main harness. Using the tester, check between the main harness and the ground.

If the tester does not light up, the problem is in the rear sill harness. Locate the short, looking for two bare wires or terminals that are crossed and repair if possible. If that cannot be found you must replace the rear sill harness. Reconnect the circuit. If the tester lights up, the shorted circuit is not in the rear sill harness and further testing is required.

#### **SHORT CIRCUIT TEST 3**

Disconnect the main harness from the 7-way receptacle. Using the tester, check between the 7-way receptacle and the ground.

If the tester does not light up, the problem is in the main harness. Locate and repair the short. Look for two bare wires or terminals crossed. (This may require replacing the main harness.) Reconnect the circuit.

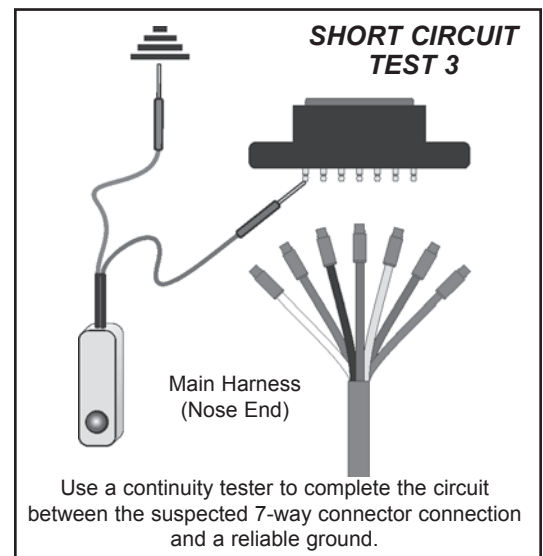
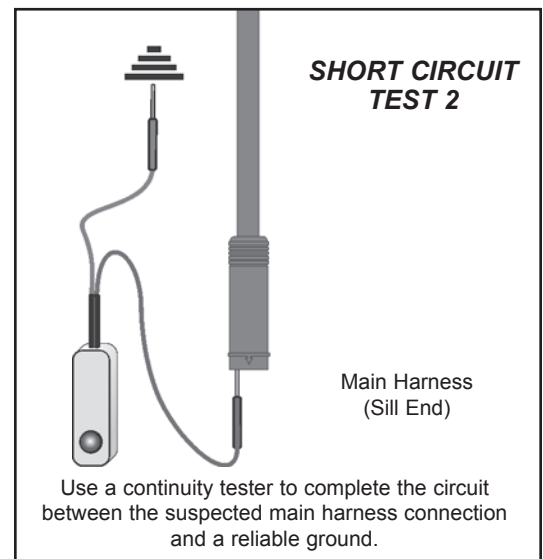
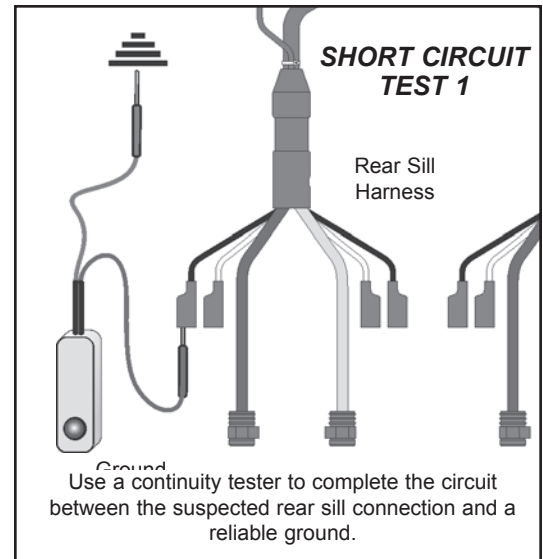

### **Troubleshooting A Grounded Circuit**

The symptoms of a grounded circuit will be intermittent circuit breaker operation or blown fuses. All the lamps in the circuit will be off. Do all testing on the circuit that is malfunctioning.

Start testing from the front of the trailer. When disconnection is required, follow the proper procedures for cleaning and using dielectric coating before reconnecting.

#### **GROUNDING CIRCUIT TEST 1**

Disconnect all connections. Disconnect the lamps from the malfunctioning circuit. Disconnect the main harness from the 7-way receptacle. Disconnect the rear sill harness from the main harness. Disconnect all appropriate jumper wires and/or pigtails from the rear sill harness.

Turn on the switch for the malfunctioning circuit. Using the tester, check the circuit between connection in question on the 7-way receptacle and the corresponding connection in the main harness.

If the tester lights up, the problem is in the main harness. Replace or repair the main harness. If the tester does not light up, the grounded circuit is not in the main harness and further testing is required.

#### **GROUNDING CIRCUIT TEST 2**

Reconnect the main harness to the 7-way receptacle. Make sure that the rear sill is not grounded. Using the tester, check the circuit between the connection in question on the main harness and the corresponding connection on the rear sill harness.

If the tester lights up the problem is in the rear harness. Replace or repair the rear still harness. If the tester does not light up, the grounded circuit is not in the rear sill harness and further testing is required.

#### **GROUNDING CIRCUIT TEST 3**

Reconnect the rear still harness to the main harness. Using the tester, check the circuit between the connection in question on the rear sill harness and the jumper wire and/or pigtail.

If the tester lights up, the problem is in the jumper wire. Replace or repair the jumper wire. After the test, make

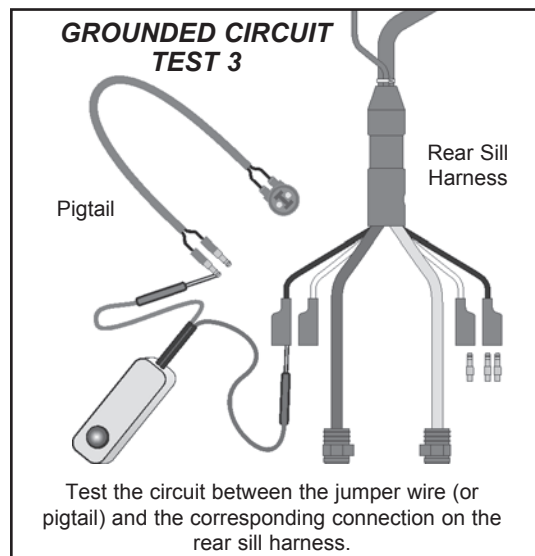
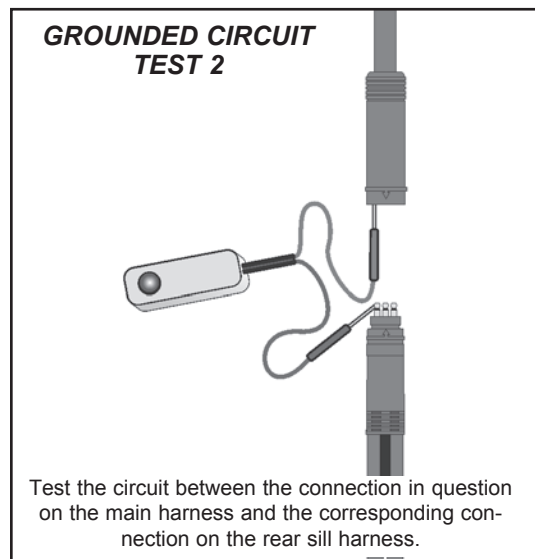
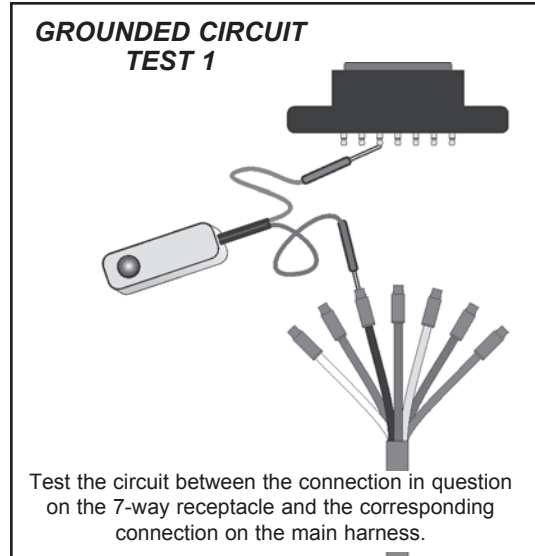

sure all connections are secure and the harness is restored to working order. Recheck all lamps in the malfunctioning circuit. Check to see that all lamps are functional and restore them to the system.

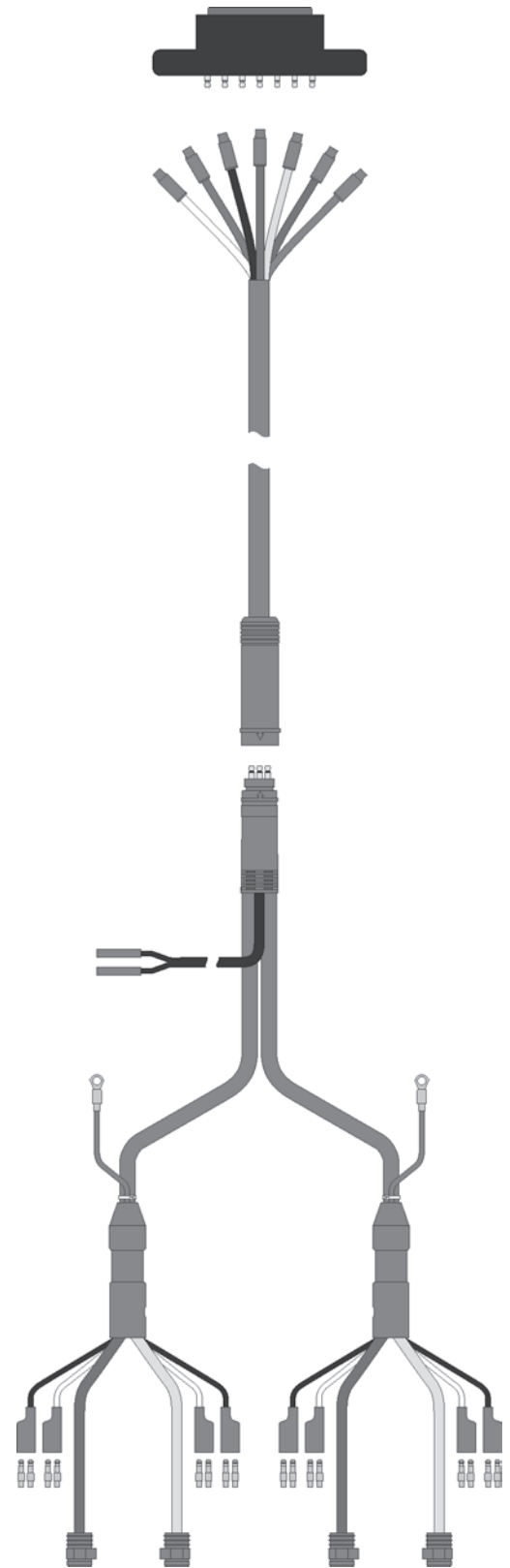

**Wiring Harness Schematic**

## Section Five Quiz Questions

1. After testing a lamp that proves to have additional life, always clean the terminals, apply a light coat of premium motor oil and reinstall. T/F
2. Before starting to trouble-shoot a trailer system, you should always: **1. F**
  - a) Wash the trailer
  - b) Check the condition of the conspicuity tape
  - c) Verify that there is power to the trailer
  - d) Remove the 7-way power cable
3. An open circuit exists when there is no ground connection because of a broken wire. T/F **2. c**
4. A chassis ground refers to a ground connection made through the wiring harness. T/F **3. T**
5. Suspect an open circuit if the circuit breaker is good and some of the lamps on that circuit are not operating. T/F **4. F**
6. Suspect a grounded circuit when lamps are operating coincidentally with those on another circuit. T/F **5. T**
7. A grounded circuit is a likely cause when the circuit breaker cycles and there is no load on the circuit. T/F **6. F**
8. Failed lamps account for \_\_\_\_\_ of all open circuits. **7. T**
  - a) 45 %
  - b) 65 %
  - c) 30 %
  - d) 90 %
9. Wires not adequately secured are a prime cause of short circuits. T/F **8. d**
10. When lamps are lighted in a circuit that should be off, it's likely that there is a: **9. T**
  - a) Grounded circuit
  - b) Open circuit
  - c) Short circuit
  - d) All of the above
11. The symptoms of a grounded circuit are intermittent circuit breaker operation or blown fuse. T/F **10. c**

**11. T**



## **Section Six**

### **Mastery Statement**

When you have successfully completed this section, you will have mastered the following:

- Understanding the malfunctioning of battery cables
- Testing battery cables
- Preventing failed battery cables
- Basic battery inspection
- Typical battery problems
- Battery testing and charging
- Safety tips

## Troubleshooting Batteries and Battery Cables

*Batteries, and the cables that connect them, operate in extremely hostile environments. By taking a moment to understand a little bit about the most common causes of failure, how to identify and repair them, as well as how to prevent them, you'll be able to make your life easier by reducing truck downtime.*

Under the hood batteries are subject to extreme heat levels and many types of chemicals, fuel and lubricants. In outside locations they're exposed to the extremes of heat and cold, and water from road splash, rain and pressure washers. Constant heavy pounding from the road sets up vibration that can loosen connections and promote damage from abrasion.

Battery cables are subject to acid vapors, which cause corrosion. It can occur wherever there are exposed metal parts. Even the use of "sealed" batteries doesn't stop corrosion since sealed batteries "breathe" through small vent openings. Corrosion can be delayed, but occurs sooner or later even where protective dielectric coating is used. As long as batteries use acid, corrosion is likely to be present.

### **Meet The Enemy – Corrosion**

Corrosion generally indicates a poor connection. When corrosion builds up, the connection deteriorates, which in turn causes more corrosion until the connection fails altogether. In the process, the poor connection causes greater resistance and less electrical energy gets through. Over time, corrosion will eat away at the connections and destroy them.

Defeating corrosion damage begins with using cables, connectors and accessories that are designed to minimize corrosion. Always use heavy-duty clamps, cables and ground lugs, where required. Lightweight clamps and components may not have the necessary load carrying capacity and will cause greater resistance, heat buildup, low current and premature failure.

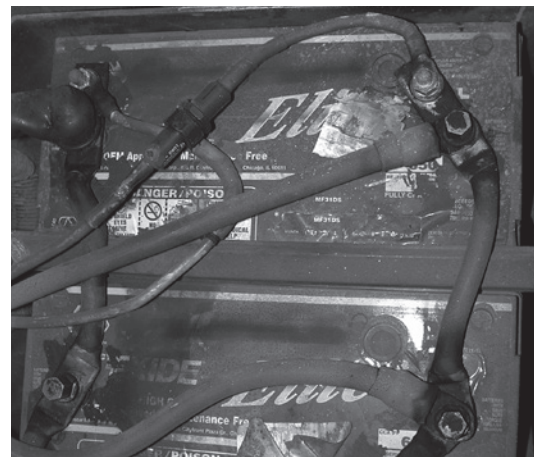

Batteries, and battery cables, operate in extremely hostile environments.

Preventing failures and poor performance can be as simple as protecting the connections and cables from damage. Shield them from moisture, battery acid and other contaminants by using shrink tubing applied to the joint where the cable is attached to the terminal.

### **Regular Inspection**

One of the most important aspects of good battery cable maintenance is regular inspection. Visually inspect the terminals where they connect to the battery. Corrosion is present when there is a buildup of a white powdery residue. Chances are that the visible buildup around the connectors is only a portion of the corrosion present. It's likely that there's additional residue under any protective covers and on the inside of the cable covering. Temporary, emergency repair terminals and inexpensive cables are especially vulnerable to corrosion. Some of this vulnerability comes from the lack of heavy lead and the lack of proper plating. It's also due in part to the tendency of inexpensive lead terminals to loosen up after being tightened on a battery post.

When servicing batteries and cables, remove visible corrosion by using a wire brush. Specially designed brushes are made to facilitate this process. One brush, with a conical shape, is used to reach inside the clamp terminal. Another, with internal bristles is used to clean the studs of the battery. Be certain to use wire brushes since using files, sandpaper or other abrasives can damage components. While it's important to thoroughly clean the battery connections, over-cleaning can wear down the soft metal.

Battery cables are also subject to abrasion. Any time a cable comes in contact with sharp edged metal parts there's the potential for scrapes and wear on the outer insulating layer. Once worn through or cut, the result can be grounding or at the very least an opening for corrosion to enter the cable. Once in the cable, corrosion can rapidly spread to the battery.

### **Cable Replacement**

Whether you should replace a battery cable or not depends upon a number of factors. However, replacement should

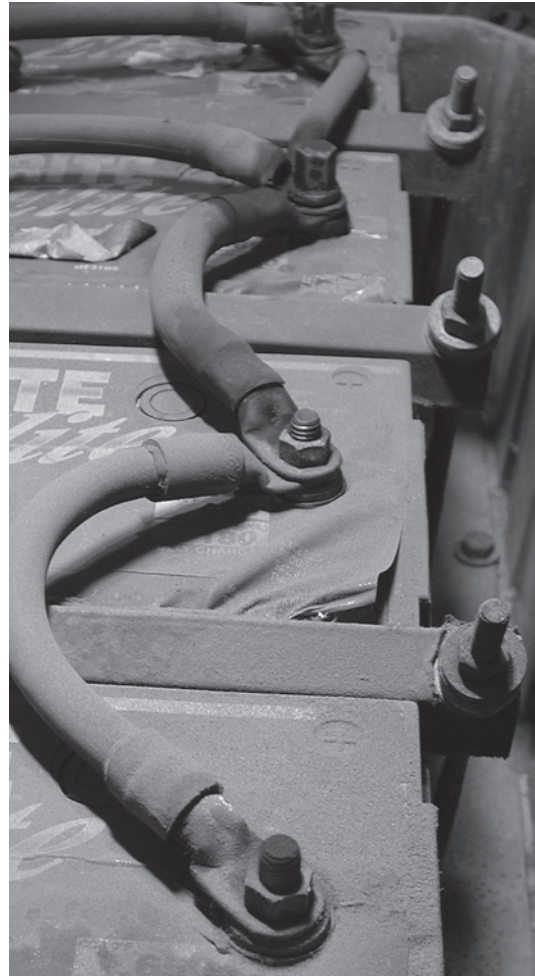

Regular visual inspections are an important part of battery maintenance.



always be considered when the battery and/or starter are replaced. Even if the cable appears all right, additional inspection steps should be taken. There are three steps for inspecting the cable.

**First**, bend the cable at a point just beyond the terminal. If that area is stiff compared to the other parts of the cable, it probably means there is corrosion in the strands of conductor. It's possible that the cable is corroded inside even if little corrosion is apparent at the terminal.

**Second**, using an ohm-meter, check to see how much resistance there is. It should be minimal. If there's significant resistance in the cable, it indicates a problem.

**Third**, crank the starter. A good battery should provide enough current to turn the starter quickly. Slow cranking and low amperage to the starter may indicate resistance from corrosion in the cable. Also, check the type of cable being used. If it's sub-standard in size or is manufactured from aluminum, it should be replaced.

When replacing a battery cable, always match the OEM specified part. Battery cables are designed to perform to certain standards. Using lower quality or mismatched parts can degrade performance resulting in substandard starting and increased maintenance. Replacement cables should always have resistance that's the same as or less than the original. Usually, matching the original means choosing a cable with the same conductor length, gauge and material.

Installing a new cable is uncomplicated. Thoroughly clean the battery terminals. Also, clean the terminals on the cable. Even though the cable is brand new, some oxidation may have coated the terminal contact areas. As when doing battery and cable maintenance, take care not to over clean the battery terminals and cable terminals. Generally, use battery terminal brushes and clean just enough to produce a fresh contact surface.

Tighten connections until they're snug. Don't over tighten because the battery posts and cable terminals can be damaged. Use a dielectric coating on all connections, even if there are protective caps. And remember that future corrosion is inevitable. Regular inspections will be necessary.

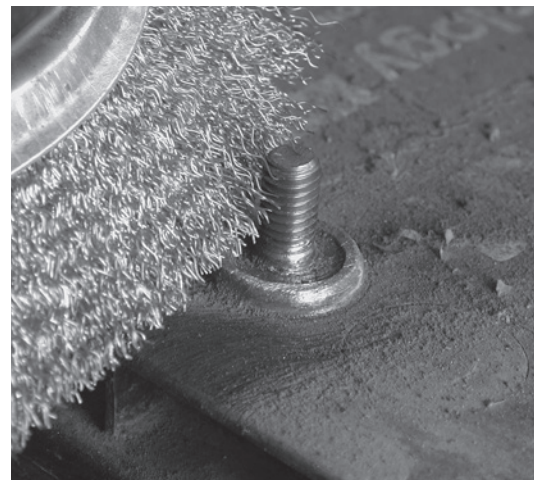

Thoroughly clean all battery terminals.

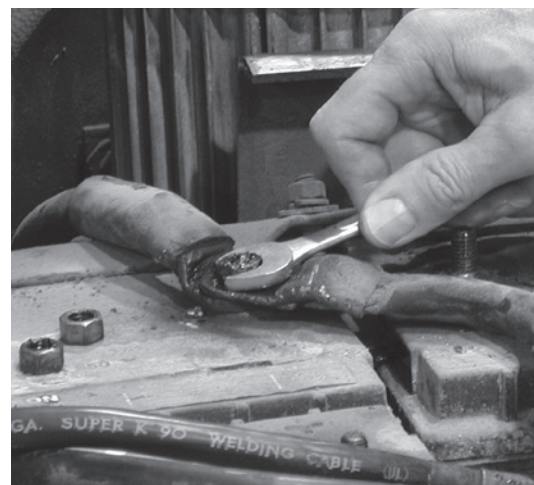

Tighten connections until they're snug.

## **BATTERY PROBLEMS & SOLUTIONS**

A malfunctioning battery is often the cause of a problem elsewhere in the electrical system. Too often though, the temptation is to simply replace the battery. Industry sources say that at least half of all discarded batteries still have service life remaining in them. For that reason, the battery is usually a good place to start the troubleshooting and repair process. Also, almost all other electrical system diagnosis procedures requires that the battery system be in proper working order.

### **Basic battery inspection**

As an example of battery troubleshooting, let's use the illustration of the starting system's inability to turn over the engine. That condition may be caused by one of several problems:

1. An inadequate or faulty charging system that leaves the battery with little or no charge.
2. Defective or "dead" battery.
3. Loose or corroded connections.
4. A "key-off" (one that bypasses the ignition switch) current draw that drains the battery.

In order to accurately determine the cause of the problem, a thorough visual inspection is a good place to begin. First, start with the battery box, the enclosure on a truck where the batteries are installed, and the battery case. Check the box for cracks or other damage that can allow the battery to become loose and experience excessive vibration. Check the battery for cracks and bulging, which can be caused by wide variations in operating environment temperatures, overcharging and over tightening the battery hold-downs. Make certain that the hold-downs are tight enough to hold the battery in place, securely. Hold-downs can, at times, become loose enough to contact the positive terminal and the metal frame of the vehicle and cause a grounded circuit.

Check for signs of corrosion on the battery, cables and connectors as well as the area around the battery. Signs of corrosion can indicate that the battery is leaking electrolyte around the posts or it has been overcharged. More typically, corrosion is caused by spilled electrolyte or



Make certain that battery hold-downs are tight enough to hold the batteries securely.

vapors from the battery vent holes. Corrosion and other contaminants attract and hold moisture, and can cause current drain if left untreated. Battery damage can occur if corrosion spreads beyond the connections.

A battery leakage test can help determine whether a battery leakage or corrosion buildup problem has been eliminated. Using a voltmeter, connect the negative test lead to the negative terminal of the battery. Place the positive lead in contact with the battery case and move it along the top and sides of the case. There should be no voltage indication anywhere on the case. If the meter does indicate voltage, a current path from one terminal to the other exists. The remedy is typically to repeat the cleaning procedure.

Battery cables are another area to check when doing a visual inspection. The insulation can become abraded and worn, exposing the conductor to moisture and corrosion. It also may lead to contact with metal components causing a grounded circuit and failure of the starting system.

A simple test for checking out poor connections between the battery terminals and cables can save considerable troubleshooting time. The “terminal test” requires that the engine be turned over without starting. For this test, disconnect the fuel supply to prevent starting.

Connect the voltmeter’s negative lead to the cable clamp and the positive lead to the positive terminal. Crank the engine. If the voltage drop exceeds 0.3v, there is high resistance at the connection. Repeat the test at the negative side of the battery. Thoroughly clean the connections and repeat the test to ensure satisfactory performance.

Another basic inspection item is the electrolyte. That fluid is required to create the chemical reaction that facilitates storage of the incoming electrical charge from the alternator. It’s also required to allow the battery plates to give up their charge when called for. The electrolyte, a mixture of distilled water and sulfuric acid should be no lower than fi inch above the top of the plates at all times. If the level is below that, it should be topped off with distilled water.

An often-overlooked inspection item is the battery date code. It can frequently shed light on the problems of a



Visually inspect the battery cables for worn insulation that will expose the conductor to moisture and corrosion.

battery and make the diagnosis of age related difficulties, such as weak charge, easier. Knowing the age can also make the decision to retain or replace the battery easier.

**Typical battery problems**

Over and under charging both present potential for battery damage or failure. If done regularly, both will shorten battery life. In fact, over-charging is reported to cause nearly 60% of the battery failures.

Some of the signs of over-charging are low electrolyte levels, elevated temperatures and corrosion at the terminals. Low electrolyte levels carry a greater concentration of acid and cause early battery plate failure. Increased internal temperatures cause plates to distort, also causing early failure. “Gassing,” the generation of hydrogen and oxygen, which occurs as a result of the chemical reactions inside the battery, is greatly increased by overcharging. The combination of hydrogen and oxygen is explosive and should not be allowed to build up. As a precaution, do not test, repair or recharge batteries in a confined space.

The primary sign of undercharging is a dull coloration of the negative plates when scratched. Most undercharging is caused by slipping belts on the alternator, long periods of idling, poor maintenance and incorrect adjustment of the voltage regulator. The results of undercharging are excessive battery cycling, low specific gravity readings, and little or no consumption of water.

Extended periods with the battery discharged may damage it. Discharging is a chemical reaction, which continues until the electrolyte has been stripped of nearly all of its sulfuric acid. The acid migrates to the plates leaving the distilled water behind. Very often, if batteries are left for long periods of time in a discharged condition, the acid on the plates will harden and not move back to the electrolyte. The condition is known as sulfation and the battery will not hold a charge, properly. Sulfation can sometimes be remedied by doing a slow charge twice. If the battery still doesn’t hold a charge, it will have to be replaced.

In some cases, installing a low-voltage disconnect to prevent over-discharging is a good investment. Another approach is to disconnect the ground connection on

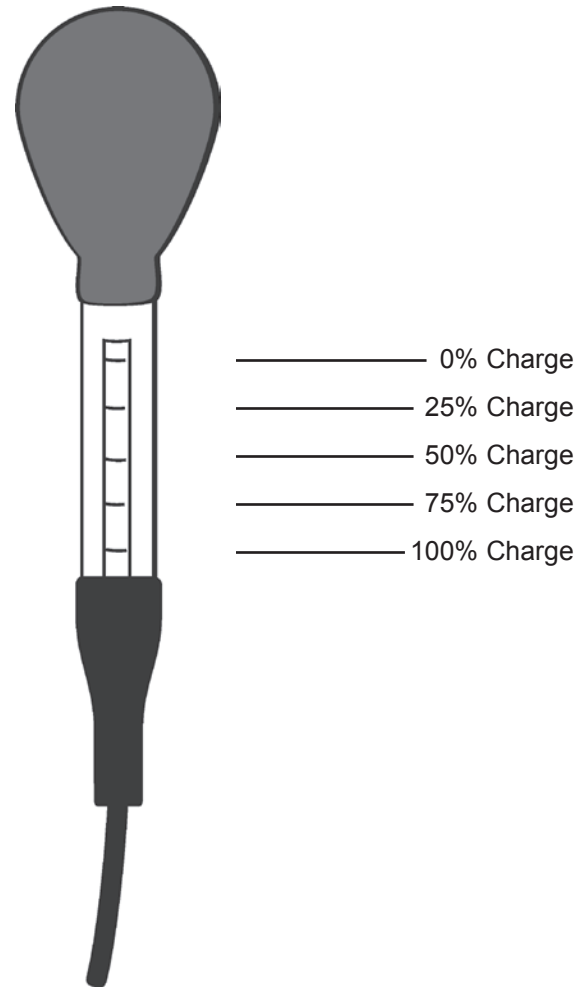

A typical hydrometer used for testing battery electrolyte.

vehicles that are left parked for two weeks or more. That avoids current drains from small parasitic electrical loads.

Vibration is one of the most prevalent causes of battery failure. It can cause plates to lose their coating, which can destroy the battery's ability to take and hold a charge. Given severe vibration, the battery case can be broken or cracked leading to loss of electrolyte. To minimize the effects of vibration, be sure to secure battery hold-downs to prevent excessive movement of the battery. Always try to mount battery boxes inside the frame rails to minimize the effects of road bounce. Experts suggest also that using batteries designed for heavy-duty applications is a good idea and a good investment over the lifetime of the battery.

Insufficient electrolyte levels also contribute to battery problems. For instance, the lack of electrolyte can accelerate sulfation making it impossible for the battery to take a full charge. If the electrolyte levels are found to be low, add distilled water (never add additional acid after the battery is filled the first time). When adding water, fill each cell to the bottom of the vent well while the battery is warm. Filling it to that level when cold will result in spillage when the plates warm up and expand.

Heavy electrical loads and low engine idle speeds are also hard on batteries. Electrical loads that exceed system's charging capacity can overwhelm the ability of the battery to supply the amount of power needed for even the most basic functions such as starting the motor on a consistent basis. That's especially true when electrical accessories have been added after the truck went into service. In those cases, a solution may be to revise the charging system and battery output. In other circumstance, it may be necessary to eliminate current consuming accessories.

An alternator belt slipping can also restrict the charging capability of the charging circuit. The slipping prevents the alternator from turning at a speed that provides the appropriate voltage to charge the battery. Unlike some of the other low battery problems, belt treatment, adjustment or replacement are relatively simple and fast remedies.

Another cause of poor battery performance is excessive voltage drop between the alternator and battery. A gener-

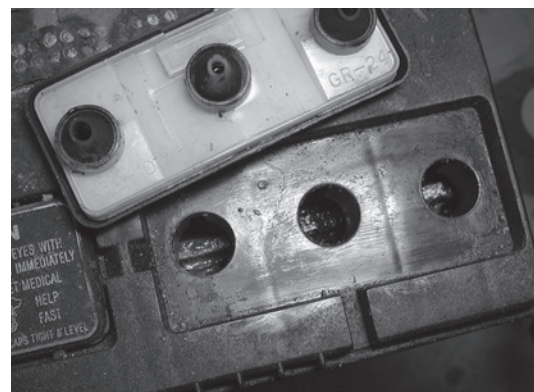

Insufficient electrolyte levels also contribute to battery problems.

ally accepted voltage-drop standard is a maximum of five volt at a 500-amp load. Troubleshooting consists of measuring the voltage drops between the charging and starting circuits. If excessive, replace the faulty cables.

Excessive heat takes a toll on batteries. To maximize service life from a battery, it should be charged and operated at temperatures below 115 degrees F. Anything above 115 and overheating occurs, which can damage the battery and shorten its normal service life. The extent of the damage and service life loss depends on how high the temperature reaches, how often the overheating occurs, and how long the batteries are subjected to high temperatures.

A typical battery charged on a correctly functioning charger will experience a 10 to 20 degree F. rise in temperature when fully charged from a completely discharged state. The temperature rise is affected by several variable factors:

1. Age and condition of the battery
2. Battery temperature compared to ambient temperature
3. Start, intermediate and finish rate of the charger
4. The amount of overcharge given the battery

Caution should be used when working with batteries. Overheating, if unchecked, can result in an explosion.

Temperatures of freezing or below can also be detrimental to battery health. In some cases, a cold battery will respond to a charge, but take significantly longer than one at warmer temperature levels. The approach in this situation is to allow the extra time required (typically one to two hours more in extremely cold temperatures).

Cold temperatures can slow down the chemical reaction that produces electrical current in the battery. As an example, a fully charged battery at 0°F can deliver only 40% of its normal capacity.

Maintaining a full charge in a battery during the winter helps to prevent a frozen battery. Nevertheless, be certain to warm up a frozen battery before charging. A weak (mostly water) electrolyte solution can cause ice crystals that can damage the plates in a battery causing an explosion hazard.

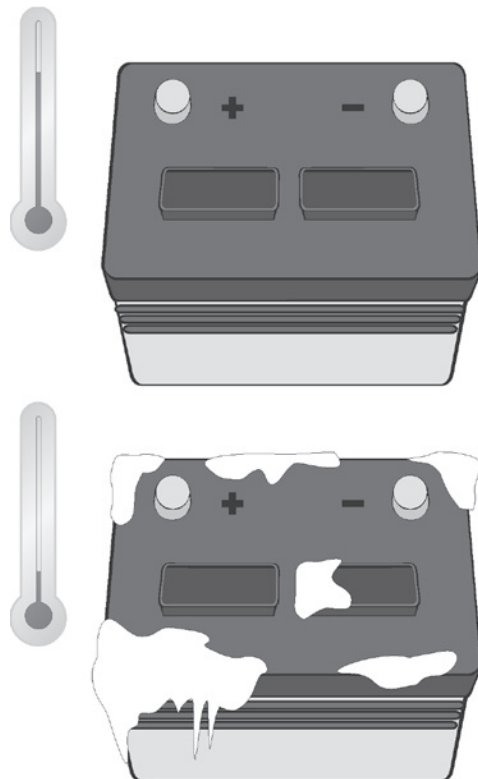

A cold battery will accept a charge, but it will take significantly longer than a warm battery.

Corrosion is another common problem that afflicts batteries. It can, however, be one of the easier ones to deal with. For example, before working on a battery, clean up any spills of electrolyte thoroughly, especially around the top and connections. That will prevent contaminants from entering when caps and cap assemblies are opened during inspection and service. Be certain to leave the battery area clean and free from corrosion, electrolyte and other contaminants when finished.

Prevent corrosion buildup on cable connectors and battery posts by covering them with a dielectric coating. Wherever possible, install covers to add more protection. It's important to keep connectors snug to batteries to prevent buildup of corrosion between a loose connector and battery post. That corrosion can then travel into the cables and eventually require new cables to be installed.

### **Battery testing & charging**

A usable battery is one that accepts and holds a charge and delivers the rated number of amps on demand. Good batteries can be recharged and returned to service. Bad batteries must be replaced. The level of charge has nothing to do with the battery's condition. It's simply a measure of how much electrical energy is available now; not how many amps are available when it is fully charged. A fully charged battery should read 12.6 volts. A reading of 12.4 volts typically equals a 75% charge. Less than that, the battery is low and requires recharging.

Some batteries have integral charge indicators. A green dot usually indicates that the battery is at least 75% charged. A dark indicator (no dot) signifies that the battery charge is low. A clear or yellow indicator means that the electrolyte is low and must be replenished before recharging. Batteries with low electrolyte must not be recharged and represent an explosive hazard. Sealed batteries cannot be replenished and must be replaced.

Batteries with integral charge indicators often are not very accurate. They only report the status of one cell. If all of the cells are good, they should carry approximately the same charge. However, if the battery has one or more bad cells, the charge level indication may not be accurate.



Clean up spills of electrolyte thoroughly, especially around the top and connections.



A fully-charged battery should read 12.6 v.

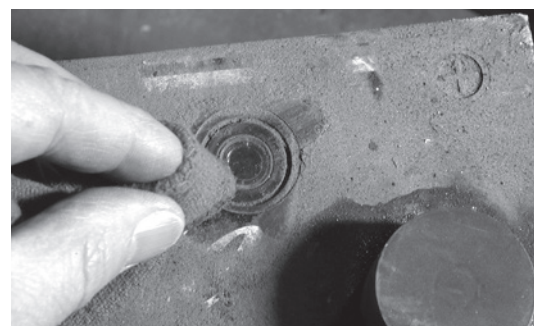

Some batteries have charge indicators.

There are certain generally used tests for diagnosing battery problems and useful life for batteries without the built-in indicators.

For example, the State of Charge test or Hydrometer tests. This test measures the specific gravity of the electrolyte solution in the battery. To perform the test, make certain that the electrolyte level is above the tops of the plates. If it is not, bring the level up by adding distilled water and charge the battery to mix the solution. Next, test the specific gravity by reading where the float scale intersects the fluid level. (An allowance must be made for temperatures that vary from 80° F, since many hydrometers are calibrated to provide a true reading at that temperature. However, temperature-compensating hydrometers are available, as well). Any corrected reading below 1.265 requires recharging or replacement.

Further testing can also be done to check the potential life of the battery. Compare the specific gravity readings of individual cells. If a variation of more than about 0.050 exists between the highest and the lowest reading, the battery probably will not hold a charge, and should be replaced.

Another test may also be used to determine the state of charge. The Open Circuit Voltage test doesn't require entering the battery case and exposing the electrolyte. That makes this test the choice if the battery is a sealed type or if the battery is difficult to access.

To test a battery, requires an accurate volt/ohm meter that has a direct current accuracy of  $\pm 0.5\%$ . Compare the reading to the Open Circuit Voltage chart to find the state of charge. A reading of less than 12.66 volts indicates either the battery requires charging or there is a shorted, weak or dead cell.

The Capacity or Load Test is used to determine a battery's ability to respond if a heavy load is placed upon it. This test is performed using a so-called "adjustable carbon pile," which places a load on the battery to determine the voltage level the it can maintain. When the load is applied, a well functioning battery should still be able to maintain a minimum voltage of at least 9.6 volts. However, an accu-

<b>Hydrometer Readings</b> at 80° F	
<b>Hydrometer Reading</b>	<b>Battery's State of Charge</b>
1.265	100%
1.225	75%
1.190	50%
1.155	25%
1.120	0%



rate test requires that the battery be recharged if it is less than 75% charged.

When the carbon pile tester is used, the test load is set at fi the battery’s cold cranking amp rating or three times it’s amp/hour rating. Because a cold battery puts out less power than a warm one, this part of the testing process must be to compensate for cold temperatures. The load is applied for 15 seconds while the output level is observed. If the battery’s voltage is at or above 9.6 volts, the battery can be returned to service. If the level drops below 9.6 volts, the battery is likely to be bad. As a double check, the battery can be recharged and tested a second time or use the Three Minute Test.

That involves testing for evidence of a sulfated battery. In the test, the battery is slow charged at 40 amps for six minutes, then checking the voltage across the terminals with the charger still on. If the voltage is above 15.5 volts, the battery is not accepting a charge. Sometimes slow charging for 20 hours can reverse the sulfated condition. If not, the battery will have to be replaced.

With these three tests, the decision tree shown here is a tool for help in making the decision to discard or return batteries to service.

Other ways of testing batteries are faster and very accurate. One example is the “Conductance Tester.” One advantage is that the technology allows testing without recharging the battery before testing. Conductance testers can render a verdict in seconds even with a fully discharged battery. That ability saves time, which can be used productively for recharging good batteries and replacing those that are not salvageable.

Conductance testers send a small alternating current through the battery. The conductance indicates how much of the plate area is available to hold and deliver power. As batteries age, the conductance levels drop. Shorts and other defects in the plates also negatively affect conductance. Measuring conductance gives an accurate idea of the battery’s condition.

Some conductance testers not only analyze the battery’s charge and condition, but its Cold Cranking Amps (CCA)

**Battery Service Decision Tree**

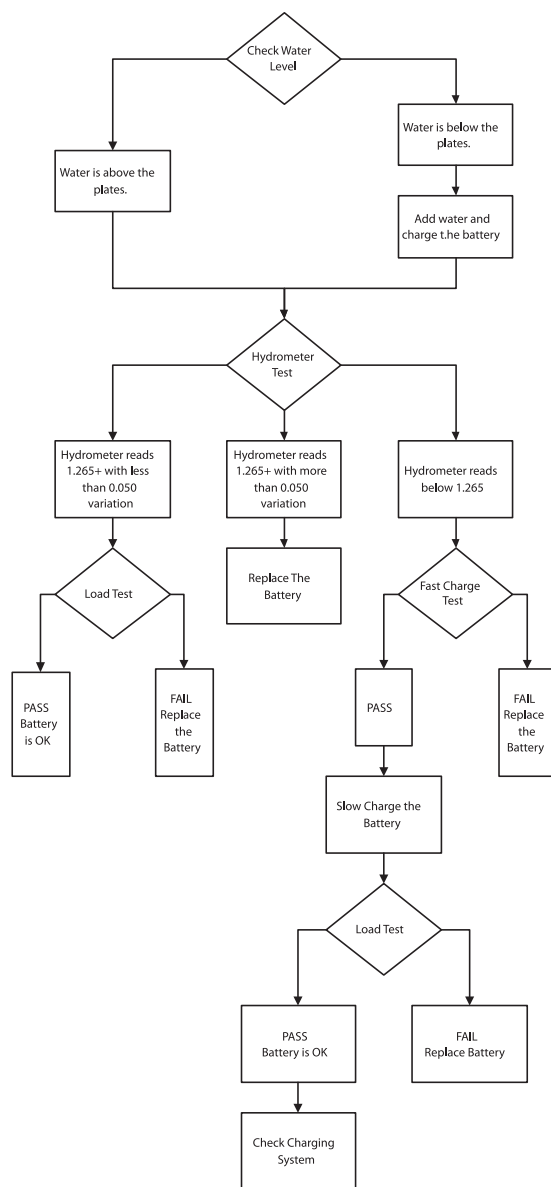

level. They may also be capable of analyzing the charging system and measuring the amps drawn by the starter while cranking the engine. Some even have built-in voltmeters, which allow them to check battery connections. Conductance testers may include the ability to detect bad or deteriorating ground connections.

No matter what means are used to test a battery, make certain that a good battery is fully recharged before returning it to service. Alternators are designed to maintain a battery's charge, not to recharge a dead one. Overtaxing the charging system with a dead battery may burden it to the point that it overheats and fails.

Battery chargers are available in many varieties from small “trickle” chargers to heavy-duty, fast chargers that can actually produce enough power to crank a large truck starter. Most chargers can fast or slow charge batteries, and offer booster output for assisted cold starts. Portable units are necessary for service calls and cart-style units are a good choice for the shop environment.

Many traditional chargers have what is referred to as “linear” charge output that gradually tapers off as the battery's charge level rises. The battery receives a full charge without overcharging, but the process takes more time than newer types of chargers. Later generations use micro-processor technology to control the charging process and optimize charging for the specific battery. It allows the battery to be charged at a faster rate and cuts the time to fully charge a dead battery by 50% or more.

The so-called “smart” chargers generally apply a high initial charging current and keep it at a high level until the battery ramps up. Then it brings down the level as the battery reaches full charge. Some of them even use a pulse-charging feature that breaks through the sulfate buildup that resists charging by ordinary means. It allows many batteries to be returned to service, which would have been discarded, in the past.

**Battery Service Safety Tips.**

- Always use caution when working with or around batteries.
- Wear eye protection and other personal protective equipment.

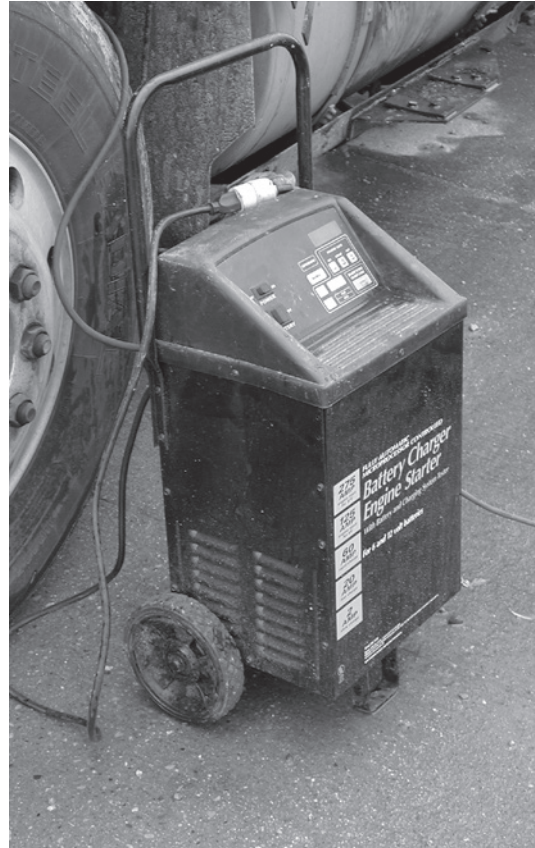

Battery chargers are available in many varieties from small “trickle” chargers to heavy-duty, fast chargers.

- Avoid splashing electrolyte (a mixture of water & acid)
- Consult manufacturer's directions for batteries, testers, charging and other equipment
- Follow manufacturer's guidelines on charging or boosting batteries
- Keep sparks and open flames away from batteries
- Avoid accidental contact between metal tools and the battery's terminals as it could cause a grounded circuit
- Always remove the ground (negative) cable first
- Never work on batteries without adequate ventilation
- After handling batteries, wash hands before eating
- Always dispose of worn-out batteries according to Federal, state and local regulations



## Section Six Quiz Questions

1. Sealed batteries prevent corrosion. T/F
2. Corrosion is a prime cause of battery cable problems. T/F **1. F**
3. Battery cables and accessories too light for the task may result in: **2. T**
  - a) Higher resistance in the system
  - b) Impaired “breathing” by sealed batteries.
  - c) Over charging
  - d) None of the above
4. Sand paper is a good substitute for battery terminal brush. T/F **3. a**
5. Battery cable replacement should always be considered when the battery and/or starter are replaced. T/F **4. F**
6. A cone shaped brush efficiently cleans battery posts. T/F **5. T**
7. The visible corrosion is likely to represent only a fraction of the total corrosion present. T/F **6. F**
8. The steps involved in inspecting a battery cable include: **7. T**
  - a) Bending the cable just beyond the terminal
  - b) Checking the resistance
  - c) Checking starter performance
  - d) All of the above
9. Replacement cables should: **8. d**
  - a) Be a color that stands out for easier inspection
  - b) Be as small as possible to make replacement easier
  - c) Be made up of as few strands as possible
  - d) None of the above
10. Generally, when cleaning terminals the more surface removed, the better. T/F **9. d**
11. Cable and battery connections should be: **10. F**
  - a) As tight as possible
  - b) Loose enough to be turned by hand
  - c) Snug
  - d) Tightened as tight as possible and backed off one turn

**11. c**

12. “Key-off” refers to current draw that goes through a light switch. T/F
13. Bulging or cracked batteries are least likely to be caused by: **12. F**
- a) Widely varying operating environment temperatures
  - b) Hold-downs which are too tight
  - c) Over charging
  - d) Wrong electrolyte
14. Corrosion is typically caused by **13. d**
- a) Leaking electrolyte
  - b) Overcharging
  - c) Electrolyte vapors
  - d) All of the above
15. A battery leakage test requires: **14. d**
- a) A voltmeter
  - b) Hydrometer
  - c) High voltage source
  - d) Sulfate
16. In a terminal test, if the voltage drops by \_\_\_\_\_ there is high resistance in the circuit: **15. a**
- a) 30.6 v or more
  - b) 0.3 v or more
  - c) 12.6 v or more
  - d) 0.003 v
17. Electrolyte is a mixture of distilled water and sulfuric acid. T/F **16. b**
18. The date code shows when the battery was last checked for electrolyte levels. T/F **17. T**
19. Over charging is reported to cause \_\_\_\_\_ of battery failures: **18. F**
- a) 60%
  - b) Over 76%
  - c) Nearly half
  - d) 22%
20. Undercharged batteries use very small amounts of water. T/F **19. a**
- 20. T**

21. To keep an unused battery from discharging, never disconnect the ground cable or strap. T/F **21. F**
22. Sulfation results when the battery plates become saturated with water. T/F **22. F**
23. After the initial filling, if the battery needs refilling: **22. F**
- a) Always add acid to regain a 50/50 mixture
  - b) Add distilled water
  - c) Add enough water to cover half the plate
  - d) Add small amounts of a water/acid mixture
24. Generally, a drop of fi volt at a 500-amp load is considered acceptable. T/F **23. b**
25. To maximize service life a battery should be charged and operated at temperatures below: **24. T**
- a) 72 degrees F
  - b) 115 degrees F
  - c) 212 degrees F
  - d) 125 degrees F
26. At 0° F a fully charged battery can deliver only \_\_\_\_\_ of its normal capacity: **25. b**
- a) 90%
  - b) 15%
  - c) 40%
  - d) 50%
27. Frozen batteries should be charged to warm them up. T/F **26. c**
28. A fully charged battery should read: **27. F**
- a) 12.6 volts
  - b) 22.4 volts
  - c) 12 volts
  - d) 10 to 11 volts
29. On a battery with a built in charge indicator a green indicator reports that the battery is at least: **28. a**
- a) 50% charged
  - b) 25% charged
  - c) 100% charged
  - d) At least 75% charged
- 29. d**
-

30. A State of Charge test requires:
- a) A volt meter
  - b) A continuity tester
  - c) Hydrometer
  - d) Hydroscope
31. A variation in specific gravity reading of more than 0.050 from cell to cell means that the battery needs replacement. T/F **30. c**
32. When using a carbon pile tester to do a load test, the tester should be set at one half of the battery's cold cranking amp rating. T/F **31. T**
33. Conductance testers send a \_\_\_\_\_ through the battery. **32. T**
- a) Small AC current
  - b) 120 volt pulse
  - c) 12 volt static charge
  - d) Small DC current
34. Conductance testers may include the ability to detect bad or deteriorating ground connectors. T/F **33. a**
35. Microprocessor controlled chargers can cut the time to recharge a dead battery by:
- a) More than 20%
  - b) About 75%
  - c) 50% or more
  - d) 33%
36. Always remove the positive connector first. T/F **35. c**

**36. F**

## **Section Seven**

### **Mastery Statement**

When you have successfully completed this section, you will have mastered how to handle:

- Total system failure.
- Single lamp outage.
- Replacing wire and cable.
- Correcting voltage problems.
- Improper grounding.
- Using proper lamps.
- Cleaning lenses.
- Proper lamp mounting.
- Eight major factors in lighting failure.



## Lighting Failure Checklist

*Never automatically assume that because a lamp has “failed,” the cause lies only with the lamp. Always try to diagnose the true source of the problem. Make certain that the repair is not simply fixing symptoms of a greater, more serious problem.*

### Basic Diagnosis

Assuming that the circuit is operating correctly, examine the lamp itself for clues to failure. For example:

- A lamp with stretched or broken filaments has typically been subjected to heavy vibration. This lighting device is a candidate for an upgrade to a shock resistant mounting to avoid the same problem in the future.
- A yellowish, bluish or white haze on the inside of the lamp indicates that the glass envelope has developed a leak.
- A dark metallic finish indicates an old age failure.
- Black sooty deposits on the inside indicate a voltage surge (temporary over-voltage) that has “burned out” the filament.

Always test LED’s (Light Emitting Diodes) before discarding them. In addition, test sealed units as well. Estimates show that as many as 40% of these discards are functioning and lamp failure is not the problem.

### Corrosion

When moisture and chemicals such as road salt are mixed together in the presence of metal components, corrosion is likely to develop. Left alone, the effects of the corrosion will eventually destroy the metal. Lamp failures due to corrosion often begin as intermittent outages and become permanent as corrosion takes over.

The most common sign of corrosion failure is a lamp and socket covered with white or greenish deposits. In lighting and wiring systems, periodic cleaning will help eliminate or slow the effects of corrosion.

Sealed lamps (that prevent corrosion from reaching the

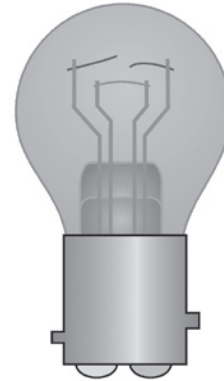

A lamp with stretched or broken filaments has typically been subjected to heavy vibration.



A yellowish, bluish or white haze on the inside of the lamp indicates that the glass envelope has developed a leak.

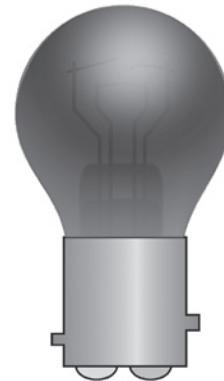

A dark metallic finish indicates an old age failure.



Black sooty deposits on the inside indicate a voltage surge (temporary over-voltage) that has “burned out” the filament.

contacts) are another approach. These are especially helpful in the presence of corrosion promoting conditions, such as saltwater and road deicer rich environments.

Use of a dielectric sealant/lubricant on all wiring connections, switches, and contacts will seal out moisture and contaminants and stop the spread of corrosion.

### **Shock & Vibration**

The constant pounding that truck components are subjected to often leads to lighting systems and lamp failure.

Lamps typically fail after the vibration and shock have weakened the filament, which ultimately breaks. The pounding effect usually results in shorter service life.

The solution is to install lamps with shock-mount mechanisms that cradle the lamp and cushion it from the effects of vibration. A good example is Grote's Torsion Mount II®.

The newest anti-shock technology is Gel-Mount® from Grote. It uses a soft gel material to hold the lamp in place while at the same time dampening the vibrations and protecting contact points from moisture and corrosion.

Another solution is to replace typical incandescent lamps with lights that eliminate filaments altogether. By switching to LED's, the problem of road shock can be completely avoided. While their initial cost may be higher, LED's are economical since they last longer. They are not affected by vibration. What's more, they're power efficient and offer superior light output.

### **Undersize Or Inadequate Wiring**

Lighting is at the "end" of the circuit. Lamp operation is limited by the electric power delivered by the wiring from the power source.

A prime source of field wiring failures is systems that are created from mis-matched components. These are often cut and spliced, merged with varied harness and wiring systems that were never designed to work together. This lack of commonality means that each problem requires much more time to troubleshoot and repair.

A system such as Grote's Ultra-Blue-Seal™ offers a sealed watertight harness system that is modular in design

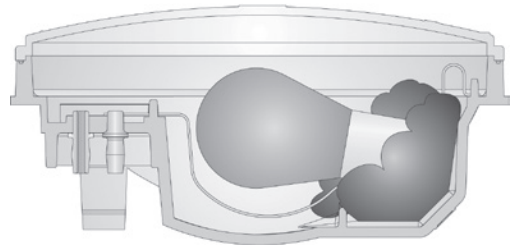

Grote's Torsion Mount II® uses a cushioning material applied around the base of a lamp to absorb vibration.



Grote Gel-Mount®, a soft cushioning material is applied around the base of the bulb to dampen vibration and shocks that could cause the bulb to fail.

and adaptable for a variety of applications. A harness system should be selected based on the power load of the vehicle and its operating application.

Quality of wire is important. Stranded copper is usually the best choice. Galvanic action can create oxides (corrosion) at crimp connections in aluminum wire that limit its capacity to conduct current. Copper resists heat better than aluminum in case of short circuits, making the threat of fire lower.

### **Poor Grounding**

Using a chassis ground is an efficient method of creating a circuit for vehicle lighting. Unfortunately, in most trailer applications, the connections from the lighting devices are open to the elements. The nature of trailer design exposes the chassis to vibrations, which tend to loosen connections, causing lamp failure.

Of course, periodic checks on chassis ground connections can alleviate some of the problem by providing warning of corrosion or loose connections in time to prevent failure. However, this inspection may not give a warning of intermittent faults.

Another approach is to use a solution such as Grote's Ultra-Blue-Seal with an integral ground system. A harness system of this type protects against ground failures by virtually eliminating exposed ground connections.

### **Excessive Voltage**

As the prior section mentioned, voltage in excess of the design level has a significant harmful effect on lamps. At the least, high voltage reduces the life of the lamps affected. In many cases, the lamps simply fail. To minimize the possibility of high voltage damage, periodically test the system voltage level to make certain it is operating in a safe range.

### **Loss Of Contact Between Lamp & Socket**

One of the biggest culprits in lighting failure is that the lamp and socket components have developed a layer of corrosion that prevents them from making sufficient contact to complete the circuit. A failure also may occur when there is a loss of spring tension in the socket.

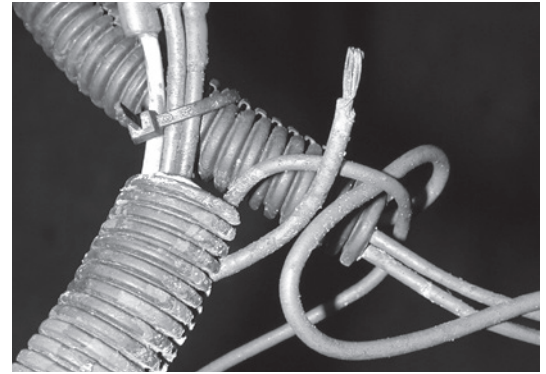

Poorly cut and spliced wires can create problems that are difficult to troubleshoot and repair.



In most trailer applications, the connections from the lighting devices are open to the elements.

One solution for loss of contact is to clean the contact points to remove any material preventing secure electrical contact. There are several products on the market that are designed to minimize this problem or delay its onset.

Grote Gel-Mount® products provide sealed contacts and a secure mounting method to hold the lamp in place even in cases of heavy vibration. Replacement with sealed units (to prevent migration of moisture and contamination) will also offer an effective long-term remedy. Another solution is to make use of robust LED technology to replace the incandescents, which are much more susceptible to corrosion and other operating condition related problems.

### ***Physical Damage***

The last common cause of lamp failure is damage from road debris impact, vandalism, collision with fixed objects (like buildings and docks) and other situations where the lamp is raised above the mounting surface.

Cleaning is another source of damage. This is due in part to pressure washing, which can drive water into lamp housings and connections. Unsuitable cleaning agents can easily cause lens softening and cracking. Use of abrasives during the cleaning process may also result in significant damage to lens and housing surfaces.

Less expensive lenses and housings often are more brittle, especially compared to polycarbonate lenses. The solution is to use stronger, damage-resistant materials. Choosing styles that feature recessed mountings will also help avoid damage in situations where surface mounts would be vulnerable. Branch deflectors offer another layer of protection from tree bough and branch impacts.



The last common cause of lamp failure is damage from road debris impact, vandalism or collision with fixed objects.

## Section Seven Quiz Questions

1. A lamp with stretched or broken filaments may well:
  - a) Indicate a voltage surge
  - b) Mean the lamp was old
  - c) Be a candidate for upgrade to a shock resistant mounting
  - d) None of the above
  
2. A white haze on the inside of a lamp typically means the glass envelope has developed a leak. T/F **1. c**
  
3. As many as \_\_\_\_\_ of sealed units presumed to have failed are actually still functional and failure is due to some other cause: **2. T**
  - a) 40%
  - b) 80%
  - c) 10%
  - d) 15%
  
4. White or greenish deposits are a sign of corrosion. T/F **3. a**
  
5. Avoid using dielectric sealant because it attracts and holds moisture. T/F **4. T**
  
6. Another cause of lamp failure is constant \_\_\_\_\_ which weakens filaments. **5. F**
  - a) Cold
  - b) Road shock
  - c) Ultraviolet light
  - d) None of the above
  
7. LED's are a good choice because: **6. b**
  - a) They cost less to operate
  - b) They provide superior light output
  - c) They are less prone to vibration damage
  - d) All of the above
  
8. Using a variety of unmatched components should have no effect on reliability. T/F **7. d**
  
9. Aluminum wire is superior to copper because it eliminates corrosion at crimps and resists heat better. T/F **8. F**

**9. F**

10. Poor grounding problems can often be traced back to:
- a) Vibration
  - b) Sealed systems
  - c) The use of heat-shrink tubing
  - d) All of the above
11. Raising system voltage a little bit is good because the lights are easier to see. **10. a**  
T/F
12. When there is loss of contact between lamp and socket, the remedy is: **11. F**
- a) Clean the contacts to remove corrosion layers
  - b) Switch to a heavier gauge wire
  - c) Wrap the socket with electrical tape
  - d) All of the above
13. One of the most common causes of lamp failure is: **12. a**
- a) Corrosion
  - b) Damage from animal strikes
  - c) Cold temperature breakage
  - d) Ultraviolet light
14. The best material for lenses and housing is: **13. a**
- a) Polypropylene
  - b) Polyvinylchloride
  - c) Polycarbonate
  - d) Polyanna
- 14. c**

Lighting Failure Checklist

---

## **Section Eight**

### **Mastery Statement**

When you have successfully completed this section, you will have mastered the following:

- How to calculate the amount of wire required to install a circuit.
- How to calculate the amount of amps a circuit will draw.
- How to determine the correct lighting installation to meet the FMVSS 108 requirements.



## Choosing The Right Wire

*In some cases, the only solution to repairing a problem is to replace a wire. In that case, it's important to follow the procedure outlined below.*

### **Determine The Length Of The Run**

Calculating the length of run requires a measurement referred to as the “most distant point.” Care must be taken to calculate the actual length. That means allowing for connections, providing slack to reach around obstacles and generally making sure that the length of run is not understated. For example, a rear trailer light mounted in the center might need to be fed from the side instead of down the center. That extra run could double the length of the wire.

With the length of run known, calculate the total amperage load by adding together the amperage draw for all of the devices that will require power on that circuit. With these two calculations complete, the correct wire size can be determined.

Using the “Wire Size” chart provided on the next page, first find the load in amps in either the first or second column. Note that the first column shows the values for a 12-volt system. The second column shows the values for a 6-volt system.

Then find the length of run across the top of the chart. If you don't find your exact length, always go to the next highest length. In other words, if your length of run is 61 feet, use the column labeled 70 feet. Read down that column until it intersects with the amp load line. The point at which they cross indicates the correct wire size for the job.

Since heat has the effect of increasing resistance and diminishing the capacity of the wire, it makes sense to determine the possible effect that the operating temperature might have on the wire choice.

To do that, find the suggested wire size (from the prior exercise) on the left edge of the “Temperature Chart” provided. On that line, read across to the temperature column that reflects the operating environment. At that intersection, read the maximum allowable amp carrying capacity.

### **Calculate The Actual Length Of Each Wire Run**

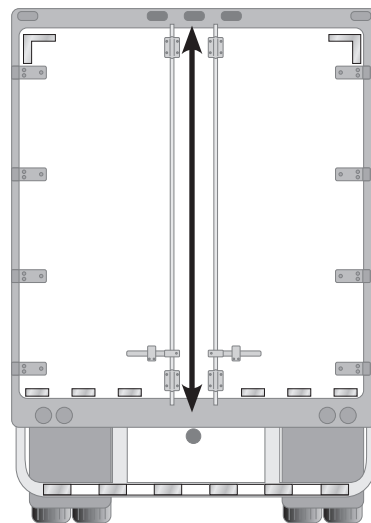

*There may be 100" between the point where the wiring harness terminates (below the floor of the trailer) and the lights (above the door) that you wish to connect. However ...*

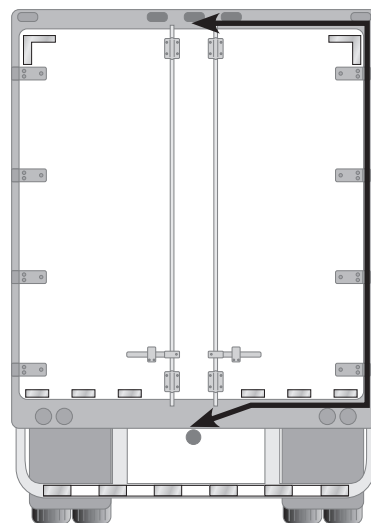

*The wire must be routed over to the side of the trailer, up the wall, and back across the ceiling to the lights. The actual run is closer to 200".*

Confirm that the maximum amp load indicated is greater than or equal to the load in the new circuit. If not, choose a heavier gauge wire and then check the temperature chart one more time.

### Truck Lighting Regulations

Although lighting is a major component of the safety equipment on any vehicle, nowhere is it more important than on trucks. There are some very specific regulations that apply to them, especially the number of lights and the placement.

The regulations that are encountered on a regular basis are contained in rules enforced by the National Highway Traffic Safety Administration (NHTSA). It's a federal agency with jurisdiction over the entire country, and it should be noted that NHTSA regulations take priority over state or local regulations.

<b>TEMPERATURE CHART</b>			
<b>Cable Size</b>	<i>Maximum Current Carrying Capacity (For 12 Volts at Listed Temperatures)</i>		
	120° F	125° F	150° F
20 Gauge	15 Amps	13 Amps	9 Amps
18 Gauge	18 Amps	15 Amps	11 Amps
16 Gauge	22 Amps	19 Amps	14 Amps
14 Gauge	27 Amps	23 Amps	17 Amps
12 Gauge	40 Amps	32 Amps	24 Amps
10 Gauge	50 Amps	42 Amps	31 Amps

**Note:** Currents above those listed may increase the temperatures of the PVC above a safe design level of 180° F.

<b>WIRE SIZE CHART</b>											
For A 12-Volt System	For A 6-Volt System	Length of Wire (Most Distant Light)									
		10'	20'	30'	40'	50'	60'	70'	80'	90'	100'
Load in Amps	Load in Amps	Wire Gauge	Wire Gauge	Wire Gauge	Wire Gauge	Wire Gauge	Wire Gauge	Wire Gauge	Wire Gauge	Wire Gauge	Wire Gauge
1.0	0.5	18	18	18	18	18	18	18	18	18	18
1.5	0.75	18	18	18	18	18	18	18	18	18	18
2.0	1.0	18	18	18	18	18	18	18	16	16	16
3.0	1.5	18	18	18	18	18	16	16	16	14	14
4.0	2.0	18	18	18	16	16	16	14	14	14	12
5.0	2.5	18	18	18	16	14	14	14	12	12	12
6.0	3.0	18	18	16	16	14	14	12	12	12	12
7.0	3.5	18	18	16	14	14	12	12	12	12	10
8.0	4.0	18	16	16	14	12	12	12	10	10	10
10.0	5.0	18	16	14	12	12	12	10	10	10	10
11.0	5.5	18	16	14	12	12	10	10	10	10	8
12.0	6.0	18	16	14	12	12	10	10	10	8	8
15.0	7.5	18	14	12	12	10	10	10	8	8	8
18.0	9.0	16	14	12	10	10	8	8	8	8	8
20.0	10.0	16	16	12	12	10	10	8	8	8	8

The Federal Motor Vehicle Safety Standard are the requirements provided by NHTSA for vehicle safety. FMVSS 108 is regulation that specifies the performance, numbers and location of lights on vehicles. The standard is referred to as FMVSS 108. The FMVSS 108 information chart (see pages 84 and 85) provides a concise explanation of the requirements and a way to become familiar with the basics of truck lighting. Let's consider how this applies to trailer setup.

The chart is based upon a grid. The information reading left to right across describes the equipment, the mandatory quantities, and other requirements. Reading from top to bottom, the chart shows the requirements beginning with what is required for all trailers in the top section. Additional requirements are triggered as a trailer's size and weight increase. Those requirements are detailed in sections of the chart below the basic requirements toward the bottom of the chart. Keep in mind that the basic requirements are fixed and that larger and heavier means adding more equipment.

A closer look at a typical line in the top section titled "Basic Equipment Required On All Trailers" section will help illustrate the information layout on the chart. One way of learning how the system works is to assume that a trailer has no lights and the task is to determine what the requirements are.

Now, let's look at the first example in the chart, found on the first row.

**Description**

The first column in the "Description" section describes the area under consideration. The first example in the chart refers to area 1. If you look at the illustrations of trailers across the bottom of the page, you'll see where area #1 is located.

In the second column, the equipment description is "Tail Lamps."

The third column contains an SAE lens code that you'll find molded into a properly designed lens. This describes the function of the lighting device as designated by the

CANADIAN MOTOR VEHICLE SAFETY STANDARDS & FEDERAL MOTOR VEHICLE SAFETY STANDARDS

**BASIC EQUIPMENT REQUIRED ON ALL TRUCKS, BUSES & MPVs**

DESCRIPTION		MANDATORY REQUIREMENTS					
Area	Equipment	SAE Lens Code	Function	Quantity	Color	Location	Height From Ground
1	Headlamps - Lower Beam US requires DOT lettering on lens US & Canada - light source code required on lens	H, HR	Forward road illumination	Minimum 2	White	On the front - symmetrical As for rear - symmetrical or above if 4 lamp system - offset and above light beams	500 - 1,270 mm 20-54 inches
	Headlamps - Upper Beam US requires DOT lettering on lens US & Canada - light source code required on lens	H, HR	Forward road illumination	Minimum 2	White or Yellow	On the front - symmetrical As for rear - symmetrical or above light beams	500 - 1,270 mm 20-54 inches
	Parking Lamps §	p	Indicate parked vehicle	Minimum 2	White or Yellow	On the front - symmetrical As for rear - symmetrical or above light beams	500 - 1,520 mm 20-54 inches
	Daytime Running Lamps (DRL) Canada - Required US - Optional (US requires "DRL" lettering on lens if not headlamp)	Y2	Indicate in use with side	Minimum 2	White or Yellow	On the front - symmetrical As for rear - symmetrical or above light beams	500 mm minimum 20 inches minimum Max. depends on type of DRL
	Front Turn Signal / Hazard Warning Lamps	I	Indicate direction of turn; identify disabled vehicle	Minimum 2	Yellow	On the front - symmetrical As for rear - symmetrical or above light beams	500 - 2,100 mm 19 - 83 inches
2	Front Clearance Lamps†	P2, PC* or P3, PC2*	Show vehicle's width	Minimum 2	Yellow	All wheel point - symmetrical on the front or rear the front being forward	As high as practicable
3	Front Identification Lamps (ID)†	P2 or P3	Indicate presence of a wide vehicle	Exactly 2	Yellow	On the front - center horizontally spaced 150 mm (6 in) to 300 mm (12 in) apart	As high as practicable or on top of the cab
4a	Front Side Marker Lamps	P2, PC* or P3, PC2*	Indicate presence of a wide vehicle	Minimum 2	Yellow	Each side of front or rear - symmetrical as practicable	500 mm minimum 20 inches minimum
4b	Front Side Reflex Reflectors	A	Front and rear side marker lamps - side reflex reflectors only	Minimum 2	Yellow	As for rear - symmetrical as practicable facing forward	500 - 750 mm 19 - 30 inches
4c	Rear Side Marker Lamps**	P2, PC* or P3, PC2*	Each side of rear - side reflex reflectors only	Minimum 2	Yellow	As for rear - symmetrical as practicable facing forward	500 mm minimum 20 inches minimum
4d	Rear Side Reflex Reflectors**	A	Each side of rear - side reflex reflectors only	Minimum 2	Yellow	As for rear - symmetrical as practicable facing forward	500 - 750 mm 19 - 30 inches
5	Rear Clearance Lamps †	P2, PC* or P3, PC2*	Show vehicle's width	Minimum 2	Yellow	All wheel point - symmetrical on the rear or rear the rear being forward	As high as practicable
5a	Rear Identification Lamps (ID) †	P2 or P3	Indicate presence of a wide vehicle	Exactly 2	Yellow	Horizontally spaced 150 mm (6 in) to 300 mm (12 in) apart facing forward	As high as practicable May be lower only if rear ID lamps are on the top
6	Tail Lamps	I	Indicate presence of a wide vehicle	Minimum 2	Red	On the rear - symmetrical As for rear - symmetrical as practicable facing forward	500 - 1,520 mm 20 - 54 inches
7	Stop Lamps	R	Indicate stopping	Minimum 2	Red	On the rear - symmetrical As for rear - symmetrical as practicable facing forward	500 - 1,520 mm 20 - 54 inches
	Rear Turn Signal / Hazard Warning Lamps	I	Indicate direction of turn; identify disabled vehicle	Minimum 2	Red or Yellow	On the rear - symmetrical As for rear - symmetrical as practicable facing forward	500 - 2,100 mm 19 - 83 inches
8	Rear Reflex Reflectors	A	Show vehicle's presence and width	Minimum 2	Yellow	On the rear - symmetrical As for rear - symmetrical as practicable facing forward	500 - 1,520 mm 19 - 30 inches
9	Backup Lamp	B	Before the ground and rear view mirror	Minimum 2	White	Rear	No requirement
10	Luxurious Plate Lamps	L	Decorative license plate	1	White	On the rear - above all of the sides of license plate	No requirement
11	Center High Mounted Stop Lamp †	S3	Indicates braking	1	Red	On the rear - centerline of the vehicle	500 mm minimum 20 inches minimum
12a	Intermediate Side Marker Lamps	P2 or P3	Indicate presence of a long vehicle	Minimum 2	Yellow	Each side rear center	500 mm minimum 20 inches minimum
12b	Intermediate Side Reflex Reflectors	A	Indicate presence of a long vehicle	Minimum 2	Yellow	Each side rear center - lighted upward	500 - 1,520 mm 19 - 50 inches

**TRUCK TRACTORS**

DESCRIPTION		MANDATORY REQUIREMENTS						
Area	Equipment	SAE Lens Code	Function	Quantity	Color	Location	Height	Options
13	Rear Upper Body Markings	DOT-C1, DOT-C2, DOT-C3, DOT-C4	Identify vehicle	Exactly 2 pairs of 300 mm long strips	White	Rear upper corners of cab facing rearward	As high as practicable	As high as practicable
14	Rear Marking	DOT-C1, DOT-C2, DOT-C3, DOT-C4	Identify vehicle	Exactly 2, each of 300 mm long strips	Red/Yellow	Rear - facing forward - on trailers, on rear box tractors, or on the top of the front	As high as practicable	If rear flag not used on the cab or frame - must be on the front of the ground

For both charts, see pages 84 and 85).

**BASIC EQUIPMENT REQUIRED ON ALL TRUCKS, BUSES & MPVs**

DESCRIPTION				
Area	Equipment	SAE Lens Code	Function	Quantity
1	Headlamps - Lower Beam US requires DOT lettering on lens US & Canada - light source code required on lens	H, HR	Forward illumination	Minimum 2
	Headlamps - Upper Beam US requires DOT lettering on lens US & Canada - light source code required on lens	H, HR	Forward illumination	Minimum 2
	Parking Lamps §	p	Indicate parked vehicle	Minimum 2
	Daytime Running Lamps (DRL) Canada - Required US - Optional (US requires "DRL" lettering on lens if not headlamp)	Y2	Indicate in use with side	Minimum 2
	Front Turn Signal / Hazard Warning Lamps	I	Indicate direction of turn; identify disabled vehicle	Minimum 2
2	Front Clearance Lamps†	P2, PC* or P3, PC2*	Show vehicle's width	Minimum 2
3	Front Identification Lamps (ID)†	P2 or P3	Indicate presence of a wide vehicle	Exactly 2
4a	Front Side Marker Lamps	P2, PC*, P3, PC2*	Indicate presence of a wide vehicle	Minimum 2
4b	Front Side Reflex Reflectors	A	Front and rear side marker lamps - side reflex reflectors only	Minimum 2
5a	Rear Side Marker Lamps**	P2, PC* or P3, PC2*	Each side of rear - side reflex reflectors only	Minimum 2

Society of Automotive Engineers (SAE), an industry professional group. The value of this permanent reference is that it helps to avoid mix-ups where two devices may appear similar, but function differently.

The fourth column describes the purpose of the device and the roll it plays in the lighting system. In this case, it is to indicate the trailer’s presence and width.

**Mandatory Requirements**

The “Mandatory Requirements” section provides information about how to use the devices identified in the “Description” section. Under “Mandatory Requirements” on the chart, the first column tells how many are required. The second column shows which colors are allowed. The third column indicates the location on the trailer body. The fourth column tells you how high the equipment shall be installed, as measured from the ground.

Reading across the seven columns shows the exact requirements under the provisions of FMVSS-108. Simply using the same approach for the remaining equipment would offer a comprehensive picture of the required equipment.

If a trailer is longer than 30 feet, refer to lines 5a and 5b under the heading “Length 9.1 m (30 ft) or longer.” If a trailer is wider than 80 inches, refer to lines 6, 7 and 8 under the heading “Width 2,032 mm (80 in) or wider.”

Also, if the gross vehicle weight is 10,000 lbs or more, the bottom section of the chart applies. These requirements are shown in a slightly different but similar format.

This last section of the chart refers to the application of “conspicuity tape.” It’s a very rugged tape consisting of highly reflective strips of alternating colors used to make a trailer easier to see. It’s used along with electric lights but greatly enhances the trailer’s visibility.

In the conspicuity section there is a “Description” section as well as a “Mandatory Requirements” section. The Mandatory Requirements section calls out the Department of Transportation (DOT) code for the tape locations and the quantity of material to be used. The other columns indicate color, location, height and any options involved in the application.

R 4,536 kg (10,000 lbs) or more		
MANDATORY REQUIREMENTS		
Color	Location	Height
White	On the rear upper corners facing rearward	At the top
Red/White	On the rear bumper bar’s horizontal element full width - facing rearward	No requirement
Red/White (See options)	On the rear full width of the vehicle facing rearward	As horizontal as practicable to close as practicable to 375 to 1,525 mm from
Red/White (See options)	Each side - facing sideward continuous, or evenly spaced over minimum of 50% of length starts and ends as close to the front and rear of the vehicle as practicable	As horizontal as practicable to close as practicable to 375 to 1,525 mm from
§ Vehicles less than 2,032 mm wide †Vehicles 2,032 mm wide or wider		

To help the visualization process, a location drawing at the bottom provides a visual resource for all of the equipment including conspicuity tape. It shows the locations described in the chart.

**Trucks, Busses & MPVs**

The same process is used to determine requirements for use of lighting and conspicuity markings on trucks and truck tractors to meet the requirements of FMVSS-108.

The practical use of the chart really becomes obvious in situations where a customer needs a replacement for a missing or damaged device.

Let’s consider the example of a stop lamp.

**Description**

First, find the description for stop lamps. The first column describes the area where the device is located. If you look at the illustrations of the trucks across the bottom of the chart, you’ll see where these areas are located. Stop lamps are in area 8.

The second column lists the equipment. Once you’ve located area 8, you’ll find that stop lamps are the second piece of equipment listed.

The third column contains the SAE lamp code (as a crosscheck with the suggested replacement).

The fourth column indicates the function of the device.

**Mandatory Requirements**

The “Mandatory Requirements” section provides the same information contained on the chart used for trailers. The first column tells how many devices are required. The second column shows which colors are allowed. The third column indicates the location on the trailer body. The fourth column tells you how high the equipment shall be installed, as measured from the ground.

Using these two charts together, your job of outfitting a truck and trailer safely and legally will be greatly simplified.

		P2, PC or P3, PC2*	MAY NOT be combined with
7	Rear Identification (ID) Lamps** †	P2 or P3	Indicate presence of a wide area
8	Tail Lamps	T	Indicate presence
	Stop Lamps	S	Indicate presence
	Rear Turn Signal/ Hazard Warning Lamps	I	Indicate direction of turn / idled
	Rear Reflex Reflectors	A	Show vehicle presence at night
9	Backup Lamp	R	Illuminate behind truck and alert following traffic
10	License Plate Lamp(s)	L	Illuminate license plate
11	Center High Mounted Stop Lamp ‡	U3	Indicates presence of vehicle

Stop lamps as described in chart on page 82.

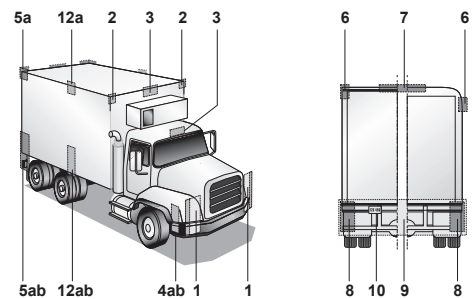

Stop lamp location (8) as shown in diagram.

# CANADIAN MOTOR VEHICLE SAFETY STANDARDS & FEDERAL MOTOR VEHICLE SAFETY STANDARDS

BASIC EQUIPMENT REQUIRED ON ALL TRUCKS, BUSES & MPVs							
DESCRIPTION				MANDATORY REQUIREMENTS			
Area	Equipment	SAE Lens Code	Function	Quantity	Color	Location	Height From Ground
1	Headlamps - Lower Beam US requires DOT lettering on lens US & Canada - light source code required on lens	H, HR	Forward road illumination	Minimum 2	White	On the front - Symmetrical As far apart as practicable If 4 lamp system - outboard or above upper beams	560 - 1,370 mm 22-54 inches
	Headlamps - Upper Beam US requires DOT lettering on lens US & Canada - light source code required on lens	H, HR	Forward road illumination	Minimum 2	White	On the front - Symmetrical If 4 lamp system - inboard or below lower beams.	560 - 1,370 mm 22-54 inches
	Parking Lamps §	P	Indicate parked vehicle	Minimum 2	White or Yellow	On the front - Symmetrical As far apart as practicable	380 - 1,530 mm 15-60 inches
	Daytime Running Lamps (DRL) Canada - Required US - Optional (US requires "DRL" lettering on lens if not headlamp)	Y2	Indicate in use vehicle	Minimum 2	White or Yellow	On the front - Symmetrical As far apart as practicable	380 mm minimum 15 inches minimum Max. depends on type of DRL
	Front Turn Signal / Hazard Warning Lamps	I	Indicate direction of turn/ identify disabled vehicle	Minimum 2	Yellow	On the front - Symmetrical As far apart as practicable	380 - 2,110 mm 15 - 83 inches
2	Front Clearance Lamps†	P2, PC* or P3, PC2*	Show vehicle's width	Minimum 2	Yellow	At widest point - symmetrical on the front or near the front facing forward	As high as practicable
3	Front Identification Lamps (ID)†	P2 or P3	Indicate presence of a wide vehicle	Exactly 3	Yellow	On the front - center horizontally spaced 150 mm (6 in) to 300 mm (12 in) apart	As high as practicable or on top of the cab
4a	Front Side Marker Lamps	P2, PC*, P3, PC2*	Front and rear side marker lamps / side reflex reflector indicate vehicle's presence and length	Minimum 2	Yellow	Each side at front as far forward as practicable	380 mm minimum 15 inches minimum
4b	Front Side Reflex Reflectors	A		Minimum 2	Yellow	At front - symmetrical as far forward as practicable facing sideward	380 - 1,530 mm 15 - 60 inches
5a	Rear Side Marker Lamps**	P2, PC* or P3, PC2*		Minimum 2	Red	Each side at rear as far back as practicable	380 mm minimum 15 inches minimum
5b	Rear Side Reflex Reflectors**	A		Minimum 2	Red	Each side at rear as far back as practicable facing sideward	380-1,530 mm 15 - 60 inches
6	Rear Clearance Lamps** †	P2, PC* or P3, PC2*		Show vehicle's width, MAY NOT be combined with tail lamps	Minimum 2	Red	At widest point - symmetrical on the rear or near the rear facing rearward
7	Rear Identification (ID) Lamps** †	P2 or P3	Indicate presence of a wide vehicle	Exactly 3	Red	On the rear - center horizontally spaced 150 mm (6 in) to 300 mm (12 in) apart facing rearward	<b>In Canada:</b> at the top - lower if door header narrower than 25 mm <b>In USA:</b> as high as practicable
8	Tail Lamps	T	Indicate vehicle's presence and width	Minimum 2	Red	On the rear - symmetrical As far apart as practicable	380 - 1,830 mm 15 - 72 inches
	Stop Lamps	S	Indicate braking	Minimum 2	Red	On the rear - symmetrical As far apart as practicable	380 - 1,830 mm 15 - 72 inches
	Rear Turn Signal/ Hazard Warning Lamps	I	Indicate direction of turn / identify disabled vehicle	Minimum 2	Red or yellow	On the rear - symmetrical As far apart as practicable	380 - 2,110 mm 15 - 83 inches
	Rear Reflex Reflectors	A	Show vehicle's presence and width	Minimum 2	Red	On the rear - symmetrical As far apart as practicable	380 - 1,1530 mm 15 - 60 inches
9	Backup Lamp	R	Illuminates ground behind the vehicle and alert road users	Minimum 1	White	Rear	No requirement
10	License Plate Lamp(s)	L	Illuminates license plate	Minimum 1	White	On the rear - above or at the sides of license plate	No requirement
11	Center High Mounted Stop Lamp ‡	U3	Indicates braking	1	Red	On the rear - centerline of the vehicle	860 mm minimum 34 inches minimum

## ADDITIONAL EQUIPMENT FOR SPECIFIC VEHICLES - VEHICLES 9.1 m (30 ft.) LONG OR LONGER

12a	Intermediate Side Marker Lamps	P2 or P3	Indicate presence of a long vehicle	Minimum 2	Yellow	Each side near center	380 mm minimum 15 inches minimum
12b	Intermediate Side Reflex Reflectors	A	Indicate presence of a long vehicle	Minimum 2	Yellow	Each side near center facing sideward	380 - 1,1530 mm 15 - 60 inches

## TRUCK TRACTORS

DESCRIPTION			MANDATORY REQUIREMENTS				
Area	Conspicuity Treatment	DOT Code	Quantity	Color	Location	Height	Options
13	Rear Upper Body Markings	DOT-C DOT-C2 DOT-C3 DOT-C4	Exactly 2 pairs of 300 mm long strips	White	Rear upper corners of cab facing rearward	As high as practicable excluding fairings	
14	Rear Marking		Exactly 2 sections of min. 600 mm each	Red/White	Rear - facing rearward - on fenders, on mud flap brackets, or within 300 mm below the top of mud flaps	As horizontal as practicable and not higher than 1,525 mm from the ground	If mud flaps not used - on the cab or frame mounted brackets

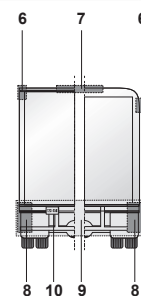
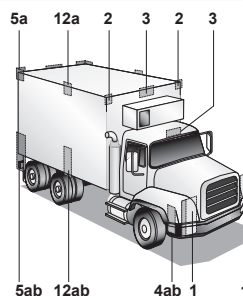
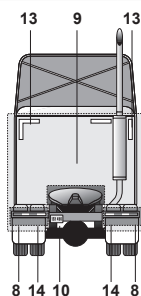
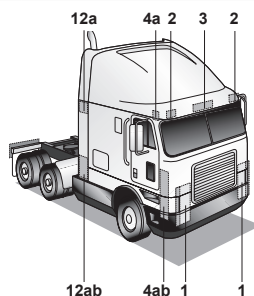

# CANADIAN MOTOR VEHICLE SAFETY STANDARDS & FEDERAL MOTOR VEHICLE SAFETY STANDARDS

BASIC EQUIPMENT REQUIRED ON ALL TRAILERS							
DESCRIPTION				MANDATORY REQUIREMENTS			
Area	Equipment	SAE Lens Code	Function	Quantity	Color	Location	Height From the Ground
1	Tail Lamps	T	Indicate vehicle's presence and width	Minimum 2	Red	On the rear - symmetrical as far apart as practicable	380 - 1,830 mm 15 - 72 inches
	Stop Lamps	S	Indicate braking	Minimum 2	Red	On the rear - symmetrical as far apart as practicable	380 - 1,830 mm 15 - 72 inches
	Rear Turn Signal Lamps	I	Indicate direction of turn	Minimum 2	Red or Yellow	On the rear - symmetrical as far apart as practicable	380 - 2,110 mm 15 - 83 inches
	Rear Reflex Reflectors	A	Indicate vehicle's presence and width	Minimum 2	Red	On the rear - symmetrical as far apart as practicable facing rearward	380 - 1,530 mm 15 - 60 inches
2	License Plate Lamp(s)	L	Illuminates license plate	Minimum 1	White	On the rear - above or at the sides of license plate	No requirement
3	Rear Side Marker Lamps	P2, PC* or P3, PC2*	Front and rear side marker lamps / side reflex reflectors indicate vehicle's presence and length	Minimum 2	Red	Each side at rear as far back as practicable	380 - 1,530 mm 15 - 60 inches no max. for veh. under 2,032 mm (80 inches) wide
	Rear Side Reflex Reflectors	A		Minimum 2	Red	Each side at rear as far back as practicable facing sideward	380 - 1,530 mm 15 - 60 inches
4a	Front Side Marker Lamps	P2, PC* or P3, PC2*		Minimum 2	Yellow	Each side at front as far forward as practicable	380 mm minimum 15 inches minimum
4b	Front Side Reflex Reflectors	A		Minimum 2	Yellow	Each side at front as far forward as practicable facing sideward	380 - 1,530 mm 15 - 60 inches

## ADDITIONAL EQUIPMENT FOR TRAILERS EXCEEDING THE FOLLOWING PARAMETERS Length 9.1 m (30 ft) or longer

5a	Intermediate Side Marker Lamps	P2 or P3	Indicate presence of a long vehicle	Minimum 2	Yellow	Each side near center facing sideward	380 mm minimum 15 inches minimum
5b	Intermediate Side Reflex Reflectors	A	Indicate presence of a long vehicle	Minimum 2	Yellow	Each side near center facing sideward	380 - 1,530 mm 15 - 60 inches

## Width 2,032 mm (80 inches) or wider

6	Rear Clearance Lamps	P2, PC* or P3, PC2*	Show vehicle's width MAY NOT be combined with tail lamps	Minimum 2	Red	At widest point - symmetrical on the rear or near the rear facing rearward	As high as practicable may be lower only if ID lamps are at the top
7	Rear Identification (ID) Lamps	P2 or P3	Indicate presence of a wide vehicle	Exactly 3	Red	On the rear - center horizontally spaced 150 mm (6 in) to 300 mm (12 in) apart facing rearward	<b>In Canada:</b> at the top - may be lower if door header narrower than 25 mm <b>In USA:</b> as high as practicable
8	Front Clearance Lamps	P2, PC* or P3, PC2*	Show vehicle's width	Minimum 2	Yellow	At widest point - symmetrical on the front or near the front facing forward	As high as practicable

## Width 2,032 mm (80 inches) or wider AND GVWR 4,536 kg (10,000 lbs) or more

DESCRIPTION			MANDATORY REQUIREMENTS				
Area	Conspicuity Treatment	DOT Code	Quantity	Color	Location	Height	Options
9	Rear Upper Body Markings	DOT-C DOT-C2 DOT-C3 DOT-C4	Exactly 2 pairs of 300 mm long strips	White	On the rear upper corners facing rearward	At the top	Reflex reflectors may not be required if they are replaced in their required location with conspicuity treatment. <b>Optional in Canada:</b> Rear lower body and side conspicuity treatment may also be solid white, solid yellow, or white and yellow.
10	Bumper Bar Marking		Continuous	Red/White	On the rear bumper bar's horizontal element full width - facing rearward	No requirement	
11	Rear Lower Body Marking		Continuous	Red/White (See options)	On the rear full width of the vehicle facing rearward	As horizontal as practicable and as close as practicable to the range of 375 to 1,525 mm from the ground	
12	Side Marking		See Location	Red/White (See options)	Each side - facing sideward continuous, or evenly spaced over minimum of 50% of length starts and ends as close to the front and rear of the vehicle as practicable	As horizontal as practicable and as close as practicable to the range of 375 to 1,525 mm from the ground	

\* Photometrically certified at installation angle    \*\* Not required on truck tractors

§ Vehicles less than 2,032 mm wide

† Vehicles 2,032 mm wide or wider

‡ Vehicles less than 2,032 mm wide and 4,536 kg

**IMPORTANT NOTE:** Every lamp, reflex reflector, and conspicuity treatment must be permanently attached in the location specified and must comply with all applicable requirements prescribed for it by FMVSS/CMVSS 108. The face of any device on the front/rear and sides should be respectively perpendicular and parallel to the vehicle's centerline unless it is photometrically certified at installation angle. No part of the vehicle shall prevent any device from meeting its prescribed requirements

unless an auxiliary device meeting all prescribed requirements is installed.

**IN CANADA:** Manufacturers and importers of vehicles must have the proper certification test records demonstrating compliance of lighting components with all prescribed requirements.

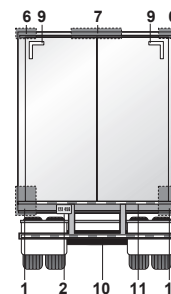
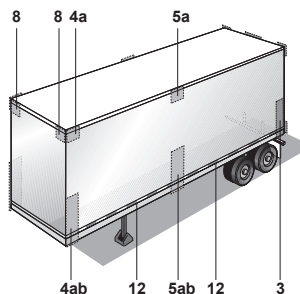
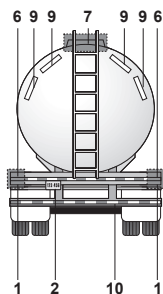
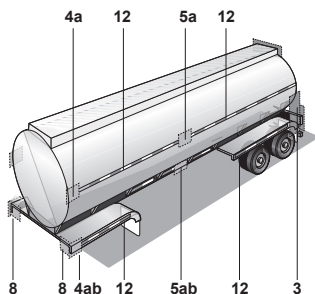

## Section Eight Quiz Questions

1. “Most distant point” refers to the distance from the source of power to the farthest circuit device measured in the most direct way possible. T/F
2. To determine the amount of current a circuit will draw, add together the current draw for all of the devices that will be attached. T/F **1. F**
3. On the wire size chart, the load in amps is displayed across the top of the chart. T/F **2. T**
4. Heat causes resistance to \_\_\_\_\_. **3. F**
  - a) Increase
  - b) Decrease
  - c) Stay the same
  - d) Disappear
5. The main set of rules that govern truck and trailer lighting comes from: **4. a**
  - a) NHTSA
  - b) ICC
  - c) FHASS
  - d) NTSB
6. On the FMVSS-108 chart, which of the following is not specified: **5. a**
  - a) Functional purpose
  - b) Location
  - c) Size of light
  - d) Color
7. Under the “Basic Equipment Required On All Trailers” a minimum of two reflectors is required on the rear. T/F **6. c**
8. For a trailer over 80 inches, three or four rear identification lamps are required. T/F **7. T**
9. On a 29 foot trailer, how many intermediate side marker lamps are required? **8. F**
  - a) A minimum of two
  - b) A maximum of four
  - c) A minimum of four
  - d) None of the above

**9. d**



10. According to FMVSS-108, license plate lights must be mounted above the plate.  
T/F
11. On an 80 inch wide trailer, the rear clearance lamps are often combined with tail lamps to save space. T/F **10. F**
12. When applying conspicuity tape on the side of a trailer, it must cover at least 50% of the length of the trailer. T/F **11. F**
- 12. T**

## Final Exam

Congratulations on completing this Grote Know-How Self Study Guide.

To complete the final exam, carefully remove the “answers” page at the end of this book by cutting along the dotted line. Fill out your personal information at the top of the page. Write your answers in the boxes provided. Fold and mail. Please allow four weeks for processing.

1. The E.A.T. principle refers to:
  - a) Assessment of corrosion
  - b) Environment and abuse
  - c) Environment, Abuse and Trouble shooting process for wiring and lighting
  - d) None of the above
2. Adding more lights to a circuit without increasing the wire gauge may cause a fire. T/F
3. Splicing several smaller pieces of wire in a circuit is better than a single length of wire. T/F
4. The best tool for applying heat to shrink tubing is a:
  - a) Butane torch
  - b) Hot air heat gun
  - c) Heat lamp
  - d) None of the above
5. Connectors shouldn't be re-used because they may:
  - a) Fit poorly
  - b) Harbor corrosion
  - c) Simply fail and allow wires to disconnect
  - d) All of the above.
6. An acceptable diagnostic technique is to use the pointed end of a continuity tester probe to puncture the insulation on a wire which makes testing faster and easier. T/F
7. The most common effect of moisture on vehicle wiring and lighting is current diverted from it's designated ground. T/F
8. The best way to seal a connection against moisture is to use
  - a) Plenty of electrical tape
  - b) A single layer of shrink tubing
  - c) A sealed system
  - d) None of the above
9. As long as a connector is not in use, it can be left open if kept isolated using electrical tape. T/F

10. Drip loops refer to:
- a) A wiring accessory that prevents water from dripping on wires under a trailer Deck
  - b) A loop left in a length of wire that allows gravity to direct water away from electrical connections
  - c) A special connector with a small loop for securing the wires away from moisture
  - d) A type of loom
11. Rapid temperature changes can cause sealed systems to draw in water. T/F
12. Battery acid corrodes most metals found in a wiring system. T/F
13. Corrosion causes :
- a) Intermittent faults that cause lights to flicker
  - b) Short circuits
  - c) Increased resistance in the circuit
  - d) All of the above
14. Contact between two dissimilar metals can cause a galvanic reaction leading to corrosion. T/F
15. Dielectric coating reverses the action of moisture and salt. T/F
16. With certain types of vibration-caused corrosion, an oxidized layer can cause intermittent failure. T/F
17. Among the ways of minimizing vibration's effects are:
- a) Using clamps to stop unnecessary movement
  - b) Securing wire as it exits a connector
  - c) Use of dielectric coating to help avoid contact wear
  - d) All of the above
18. Abrasion can be minimized by properly securing wires, keeping them away from sharp components and using loom, convoluted tubing and other protective devices. T/F
19. Trailer wiring should never be used as a step or to support a load. T/F
20. Repeatedly flexing copper strands will strengthen them. T/F
21. Tape, especially electrical tape, is the correct product to use for securing wire bundles. T/F
22. Heat shrink tubing is used to protect connections from:
- a) Moisture and corrosion
  - b) Stress
  - c) Abrasion
  - d) All of the above

23. When applying heat to a piece of shrink tube always start at the center to ensure that all moisture is forced out of the connection, working your way out to insure a proper seal. T/F
24. Convulated tubing offers:
- a) A way to organize wires
  - b) Protection from the environment
  - c) Ease of access
  - d) All of the above
25. Tubing size should be selected so that the wire fills it to approximately \_\_\_\_\_ of its diameter:
- a) 50%
  - b) 100%
  - c) 25%
  - d) 80%
26. Which of the following is not recommended for controlling and protecting wires and bundles?
- a) Fibre loom
  - b) Spiral wrap
  - c) Plastic loom
  - d) PVC tape
27. The drawback to using nylon clamps is that they are prone to rust and corrosion. T/F
28. Support points for wire bundles should be spread:
- a) From 6 inches to 12 inches
  - b) From 2 feet to 3 feet
  - c) From 12 inches to 18 inches
  - d) From 18 inches to 24 inches
29. If just one lamp is not working, the best approach is to replace it and move on. T/F
30. For electrical work, the best solder is:
- a) Resin core
  - b) Acid core
  - c) PVC core
  - d) None of the above
31. Wicking takes place when water travels along the outside of a wire's insulation. T/F
32. Increasing the current level in a circuit means:
- a) You can get by with a thinner wire
  - b) The lamps will be brighter
  - c) Wire is likely to run hotter
  - d) All of the above

33. Using splices in a circuit is preferable to single piece of wire because it's easier to isolate a problem on that circuit. T/F
34. Normal voltage at the nose of the trailer should be:
- a) 22.5 volts
  - b) 12.5 volts
  - c) 13.6 volts
  - d) 11.5 volts
35. A chassis ground uses \_\_\_\_\_ as a ground:
- a) The battery
  - b) Connection to the vehicle structure
  - c) The light switch
  - d) All of the above
36. Polycarbonate parts are impervious to cleaning products. T/F
37. Replacing a dome lamp with a backup lamp can be dangerous because of the high heat out put of the backup lamp. T/F
38. Failure to mount a lamp marked with the word "Top" with the correct orientation can result in as much as 25% shorter lamp life. T/F
39. An open circuit exists when there is no ground connection because of a broken wire. T/F
40. Suspect an open circuit if the circuit breaker is good and some of the lamps on that circuit are not operating. T/F
41. Suspect a grounded circuit when lamps are operating coincidentally with those on another circuit. T/F
42. A grounded circuit is a likely cause when the circuit breaker cycles and there is no load on the circuit. T/F
43. Sealed batteries prevent corrosion. T/F
44. Battery cables and accessories too light for the task may result in:
- a) Higher resistance in the system
  - b) Impaired "breathing" by sealed batteries.
  - c) Over charging
  - d) None of the above
45. Sand paper is a good substitute for battery terminal brush. T/F

46. Battery cable replacement should always be considered when the battery and/or starter are replaced. T/F
47. The visible corrosion is likely to represent only a fraction of the total corrosion present. T/F
48. The steps involved in inspecting a battery cable include:
- a) Bending the cable just beyond the terminal
  - b) Checking the resistance
  - c) Checking starter performance
  - d) All of the above
49. Generally, when cleaning terminals the more surface removed, the better. T/F
50. Cable and battery connections should be:
- a) As tight as possible
  - b) Loose enough to be turned by hand
  - c) Snug
  - d) Tightened as tight as possible and backed off one turn
51. Bulging or cracked batteries are least likely to be caused by:
- a) Widely varying operating environment temperatures
  - b) Hold-downs which are too tight
  - c) Over charging
  - d) Wrong electrolyte
52. Corrosion is typically caused by
- a) Leaking electrolyte
  - b) Overcharging
  - c) Electrolyte vapors
  - d) All of the above
53. A battery leakage test requires:
- a) A voltmeter
  - b) Hydrometer
  - c) High voltage source
  - d) Sulfate
54. Electrolyte is a mixture of distilled water and sulfuric acid. T/F
55. The date code shows when the battery was last checked for electrolyte levels. T/F

56. After the initial filling, if the battery needs refilling:
- a) Always add acid to regain a 50/50 mixture
  - b) Add distilled water
  - c) Add enough water to cover half the plate
  - d) Add small amounts of a water/acid mixture
57. Generally, a drop of fi volt at a 500-amp load is considered acceptable. T/F
58. On a battery with a built in charge indicator , a green indicator reports that the battery is at least:
- a) 50% charged
  - b) 25% charged
  - c) 100% charged
  - d) At least 75% charged
59. A variation in specific gravity reading of more than 0.050 from cell to cell means that the battery needs replacement. T/F
60. Always remove the positive connector first. T/F
61. A lamp with stretched or broken filaments may well:
- a) Indicate a voltage surge
  - b) Mean the lamp was old
  - c) Be a candidate for upgrade to a shock resistant mounting
  - d) None of the above
62. A white haze on the inside of a lamp typically means the glass envelope has developed a leak. T/F
63. White or greenish deposits are a sign of corrosion. T/F
64. LED's are a good choice because:
- a) They cost less to operate
  - b) They provide superior light output
  - c) They are less prone to vibration damage
  - d) All of the above
65. Aluminum wire is superior to copper because it eliminates corrosion at crimps and resists heat better. T/F

66. When there is loss of contact between lamp and socket, the remedy is:
- a) Clean the contacts to remove corrosion layers
  - b) Switch to a heavier gauge wire
  - c) Wrap the socket with electrical tape
  - d) All of the above
67. To determine the amount of current a circuit will draw, add together the current draw for all of the devices that will be attached. T/F
68. Heat causes resistance to \_\_\_\_\_.
- a) Increase
  - b) Decrease
  - c) Stay the same
  - d) Disappear
69. The main set of rules that govern truck and trailer lighting comes from:
- a) NHTSA
  - b) ICC
  - c) FHASS
  - d) NTSB
70. On the FMVSS-108 chart, which of the following is not specified:
- a) Functional purpose
  - b) Location
  - c) Size of light
  - d) Color
71. On a 29 foot trailer, how many intermediate side marker lamps are required?
- a) A minimum of two
  - b) A maximum of four
  - c) A minimum of four
  - d) None of the above
72. When applying conspicuity tape on the side of a trailer, it must cover at least 50% of the length of the trailer. T/F



# Answer Sheet

**STEP 1:** Fill out the personal information below. Please print clearly

Name: \_\_\_\_\_

Title: \_\_\_\_\_

Company: \_\_\_\_\_

Address 1: \_\_\_\_\_

Address 2: \_\_\_\_\_

City: \_\_\_\_\_

State or Province: \_\_\_\_\_ Postal Code: \_\_\_\_\_

**STEP 2:** Fill in your answers in the box to the right of the question number.

1		13		25		37		49		61	
2		14		26		38		50		62	
3		15		27		39		51		63	
4		16		28		40		52		64	
5		17		29		41		53		65	
6		18		30		42		54		66	
7		19		31		43		55		67	
8		20		32		44		56		68	
9		21		33		45		57		69	
10		22		34		46		58		70	
11		23		35		47		59		71	
12		24		36		48		60		72	

**STEP 3:** Fold this page in thirds, affix the appropriate postage, and drop it in the mail. Allow four weeks for processing.

**IN CANADA:** Please fax this page to 800-267-9024

CUT ALONG THIS LINE

Fold along this line first

Place  
Postage  
Here

Grote Industries  
2600 Lanier Drive  
Madison, IN 47250

ATTN: Marketing Department

Then fold along this line and tape closed.



**Grote Industries, Inc.**  
2600 Lanier Drive  
Madison, Indiana 47250  
USA  
Phone: 812-273-1296  
Phone: 800-628-0809  
Fax: 812-265-8440  
Email: [safety@grote.com](mailto:safety@grote.com)

**Grote Industries, Co.**  
230 Travail Road  
Markham, Ontario L3S 3J1  
Canada  
Phone: 905-209-9744  
Phone: 800-268-5612  
Fax: 905-209-9757  
Fax: 800-267-9024  
Email: [canada@grote.com](mailto:canada@grote.com)

**Grote Comercial Latinoamérica  
S. de R.L. de C.V.**  
Ave. Rogelio González  
Caballero 225  
Parque Industrial Stiva Aeropuerto  
Apodaca, Nuevo León  
México  
Código Postal 66600  
Phone: 011 (52) 81-8262-4400  
Fax: 011 (52) 81-8262-4404  
Email: [mexico@grote.com](mailto:mexico@grote.com)

**Grote Industries Europe GmbH**  
Am Schaidweg 3  
D-94559 Niederwinkling  
Germany  
Phone: +49 9962 / 20008-0  
Email: [europa@grote.com](mailto:europa@grote.com)

**Grote (Shanghai) Vehicle  
Lighting Systems Co., Ltd.**  
485 Xin Run Road, Xinqiao Township,  
Song Jiang, Shanghai, China 201612  
Phone: +86.21.5774.9633  
Email: [asia@grote.com](mailto:asia@grote.com)

