

Installation and Operation Instructions

360° LED Beacon

LED beacons are specifically designed for use in the most demanding applications, including those where severe vibration is present. These beacons meet SAE J845 Class I specifications and feature encapsulated electronics to provide superior protection against dust and moisture ingress as well as vibration and minor impacts. Available in 5" or 7" height profiles, specifications include 12-24 VDC operation, 11 flash patterns and a coated aluminum base with 3 bolt mounting flange and an integrated 1" pipe mount.



IMPORTANT! Read all instructions before installing and using. Installer: This manual must be delivered to the end user.

WARNING!

Failure to install or use this product according to manufacturers recommendations may result in property damage, serious bodily/personal injury, and/or death to you and those you are seeking to protect!



Do not install and/or operate this safety product unless you have read and understand the safety information contained in this manual.

1. Proper installation combined with operator training in the use, care, and maintenance of emergency warning devices are essential to ensure the safety of you and those you are trying to protect.
2. Exercise caution when working with live electrical connections.
3. This product must be properly grounded. Inadequate grounding and/or shorting of electrical connections can cause high current arcing, which can cause personal injury and/or severe vehicle damage, including fire.
4. Proper placement and installation are vital to the performance of this warning device. Install this product so that output performance of the system is maximized and the controls are placed within convenient reach of the operator so that s/he can operate the system without losing eye contact with the roadway.
5. It is the responsibility of the vehicle operator to ensure during use that all features of this product work correctly. In use, the vehicle operator should ensure the projection of the warning signal is not blocked by vehicle components (i.e., open trunks or compartment doors), people, vehicles, or other obstructions.
6. The use of this or any other warning device does not ensure all drivers can or will observe or react to a warning signal. Never take the right-of-way for granted. It is your responsibility to be sure you can proceed safely before entering an intersection, driving against traffic, responding at a high rate of speed, walking on or around traffic lanes.
7. This equipment is intended for use by authorized personnel only. The user is responsible for understanding and obeying all laws regarding warning signal devices. Therefore, the user should check all applicable city, state, and federal laws and regulations. The manufacturer assumes no liability for any loss resulting from the use of this warning device.

Specifications:

Size: 6.0" dia. x 4.8" high
6.0" dia. x 5.8" high

Weight: approx. 2.4 lbs.

Input Voltage: 12-24 VDC system

Input Current:
High intensity mode:
3.6 amps @ 12.8 VDC
Maximum power consumption: 46 Watts

Temp. Range: -30°C to +50°C

Installation & Mounting:

Important! This unit is a safety device, and it must be connected to its own separate, fused power point to assure its continued operation should any other electrical accessory fail.

Carefully remove the beacon and place it on a flat surface. Examine the unit for transit damage, and locate all parts. If damage is found, or parts are missing, contact the transit company or manufacturer. Do not use damaged or broken parts.



Caution: When drilling into any vehicle surface, make sure that the area is free from any electrical wires, fuel lines, vehicle upholstery, etc. that could be damaged.



WARNING!

Failure to follow these instructions can result in fire or injury from excessive heat build up.

Operator is responsible for ensuring cigarette adapter fits correctly into cigarette/auxillary outlet used. For proper operation, verify cigarette/auxillary outlet circuit is rated to supply, a minimum of 10 amps. (See specifications section for rated current in amperes).
Do not exceed the current rating for the cigarette lighter power outlet recommended by vehicle manufacturer.
Keep cigarette lighter adapter, and outlet, clean and free of debris.
Do not use the cigarette lighter adapter when wet.
Insert cigarette lighter adapter fully into the outlet for proper connection.
Grasp cigarette lighter adapter, NOT cord, to remove from outlet.
Remove cigarette lighter adapter completely from outlet when light is not in use.

Permanent Mounting:

Select the desired location on a flat surface for the strobe beacon to be mounted. The visibility of the flash and ease of wiring access should be taken into consideration in the selection of the mounting location.

1. Using the base gasket as a template, mark the three mounting hole locations (see Figure 1).
2. Drill the holes using a 7/32" drill size.
3. A fourth hole may be drilled for wire access as shown in Figure 1, or the wires may be routed through the slot in the base for external access.
4. Connect the power wires as shown in the wiring section (see Figure 3).
5. Mount the strobe with #8 hardware.

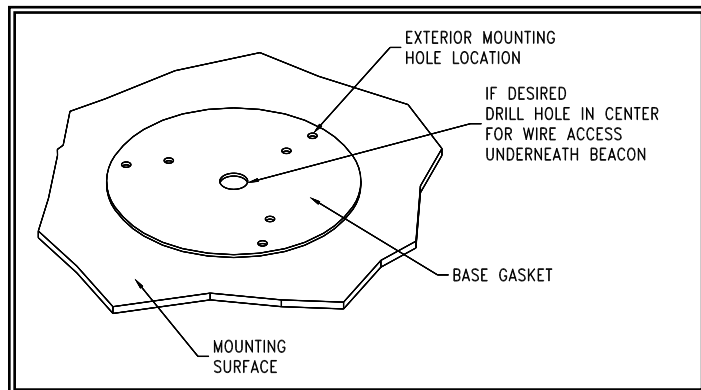

Figure 1

Pipe Mounting:

The base comes with 1" NPT threads for pipe mounting.

Wiring Instructions:

Notes:

1. Larger wires and tight connections will provide longer service life for components. For high current wires it is highly recommended that terminal blocks or soldered connections be used with shrink tubing to protect the connections. Do not use insulation displacement connectors (e.g., 3M Scotchlock type connectors).
2. Route wiring using grommets and sealant when passing through compartment walls. Minimize the number of splices to reduce voltage drop. High ambient temperatures (e.g., under-hood) will significantly reduce the current carrying capacity of wires, fuses, and circuit breakers. All wiring should conform to the minimum wire size and other recommendations of the manufacturer and be protected from moving parts and hot surfaces. Looms, grommets, cable ties, and similar installation hardware should be used to anchor and protect all wiring.
3. Fuses or circuit breakers should be located as close to the power takeoff points as possible and properly sized to protect the wiring and devices.
4. Particular attention should be paid to the location and method of making electrical connections and splices to protect these points from corrosion and loss of conductivity.
5. Ground termination should only be made to substantial chassis components, preferably directly to the vehicle battery.
6. Circuit breakers are very sensitive to high temperatures and will "false trip" when mounted in hot environments or operated close to their capacity.

Important: Disable power before wiring the beacon.

The wiring configuration is shown in Figure 2 below. All wiring should be a minimum of 18AWG. A switch may be used to control the on/off function. The black (negative) wire is connected to the battery ground.

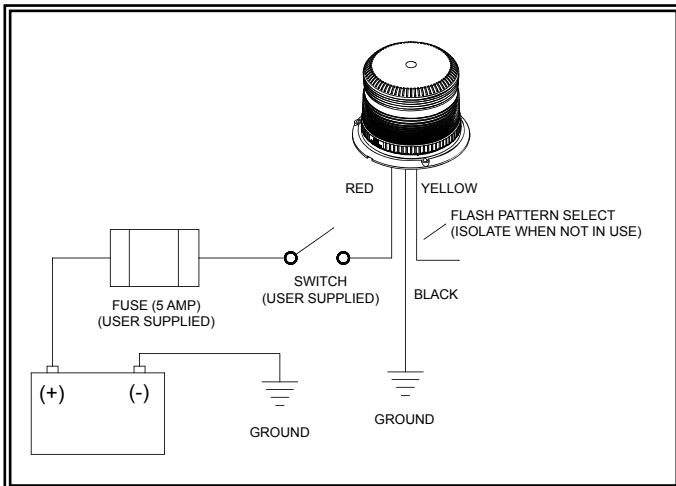

Figure 2

Flash Pattern Selection:

Flash patterns can be selected by touching the yellow wire to the red power wire for less than a second. Contacting the yellow and red wires for longer than a second toggles to the preceding flash pattern.

Maintenance:

This LED beacon has been designed for trouble free operation. There are no periodic maintenance needs for this model.

Troubleshooting:

1. Most beacon failures, including intermittent or erratic operation as well as failure of operation can be traced to wiring or battery problems. Check all wiring, connections, fuse, switch, and battery voltage to insure that the correct voltage is reaching the beacon.
2. If this has not remedied the problem, return product to your local dealer for warranty replacement.

Note: Operating the vehicle without the lens installed on this product will result in damage that will not be covered under warranty.

#	Pattern	FPM	AMBER	BLUE	CLEAR	RED
1	Single	60				N/A
2	Single	120	CLASS 1		CLASS 1	N/A
3	Double	80	CLASS 1	CLASS 1	CLASS 1	N/A
4	Double	122	CLASS 1		CLASS 1	N/A
5	Triple	75	CLASS 1		CLASS 1	N/A
6	Quad	75	CLASS 1	CLASS 1	CLASS 1	N/A
7	Quad	122	CLASS 1		CLASS 1	N/A
8	Quint Hold	75	CLASS 1	CLASS 1	CLASS 1	N/A
9	Pulse 8	75	CLASS 1	CLASS 1	CLASS 1	N/A
10	Random	N/A	N/A	N/A	N/A	N/A
11	Steady	N/A	N/A	N/A	N/A	N/A

Manufacturer Limited Warranty and Limitation of Liability:

Manufacturer warrants that on the date of purchase this product will conform to Manufacturer's specifications for this product (which are available from the Manufacturer upon request), and Manufacturer further warrants that this product is free from defects in materials and workmanship. This Limited Warranty extends for twenty-four (24) months from the date of purchase. Other warranties may apply, call Manufacturer for details. Manufacturer will, at its discretion, repair or replace any product found by the Manufacturer to be defective and subject to this Limited Warranty.

DAMAGE TO PARTS OR PRODUCTS RESULTING FROM TAMPERING, ACCIDENT, ABUSE, MISUSE, NEGLIGENCE, UNAPPROVED MODIFICATIONS, FIRE OR OTHER HAZARD; IMPROPER INSTALLATION OR OPERATION; OR NOT BEING MAINTAINED IN ACCORDANCE WITH THE MAINTENANCE PROCEDURES SET FORTH IN MANUFACTURER'S INSTALLATION AND OPERATING INSTRUCTIONS VOIDS THIS LIMITED WARRANTY.

ORAL STATEMENTS OR REPRESENTATIONS ABOUT THE PRODUCT WHICH MAY HAVE BEEN MADE BY SALESPEOPLE, DEALERS, AGENTS OR OTHER MANUFACTURER'S REPRESENTATIVES DO NOT CONSTITUTE WARRANTIES. THIS LIMITED WARRANTY MAY NOT BE AMENDED, MODIFIED, OR ENLARGED EXCEPT BY A WRITTEN AGREEMENT SIGNED BY AN AUTHORIZED OFFICIAL OF MANUFACTURER WHICH EXPRESSLY REFERS TO THIS LIMITED WARRANTY.

Exclusion of Other Warranties:

MANUFACTURER MAKES NO OTHER WARRANTIES, EXPRESS OR IMPLIED. THE IMPLIED WARRANTIES FOR MERCHANTABILITY OR FITNESS FOR A PARTICULAR PURPOSE ARE HEREBY EXCLUDED AND SHALL NOT APPLY TO THE PRODUCT. BUYER'S SOLE AND EXCLUSIVE REMEDY IN CONTRACT, TORT, OR UNDER ANY OTHER THEORY AGAINST MANUFACTURER REGARDING THE PRODUCT AND ITS USE SHALL BE THE REPLACEMENT OR REPAIR OF THE PRODUCT AS DESCRIBED ABOVE.

Limitation of Liability:

IN THE EVENT OF LIABILITY FOR DAMAGES ARISING OUT OF THIS LIMITED WARRANTY OR ANY OTHER CLAIM RELATED TO THE MANUFACTURER'S PRODUCTS, MANUFACTURER'S LIABILITY FOR DAMAGES SHALL BE LIMITED TO THE AMOUNT PAID FOR THE PRODUCT AT THE TIME OF THE ORIGINAL PURCHASE. IN NO EVENT SHALL MANUFACTURER BE LIABLE FOR LOST PROFITS, THE COST OF SUBSTITUTE EQUIPMENT OR LABOR, PROPERTY DAMAGE, OR OTHER SPECIAL, CONSEQUENTIAL, OR INCIDENTAL DAMAGES BASED UPON ANY CLAIM FOR BREACH OF CONTRACT, IMPROPER INSTALLATION, NEGLIGENCE, OR OTHER CLAIM, EVEN IF MANUFACTURER OR A MANUFACTURER'S REPRESENTATIVE HAS BEEN ADVISED OF THE POSSIBILITY OF SUCH DAMAGES. MANUFACTURER SHALL HAVE NO FURTHER OBLIGATION OR LIABILITY WITH RESPECT TO THE PRODUCT OR ITS SALE, OPERATION AND USE, AND MANUFACTURER NEITHER ASSUMES NOR AUTHORIZES THE ASSUMPTION OF ANY OTHER OBLIGATION OR LIABILITY IN CONNECTION WITH SUCH PRODUCT.

This Limited Warranty defines specific legal rights. You may have other legal rights which vary from state to state. Some states do not allow the exclusion or limitation of incidental or consequential damages.