

NEW | LED Directional Light

High-Intensity Class I LED Directional Light, Surface Mount

▶▶ NOW AVAILABLE!

LED directional light offers maximum performance in small footprint!

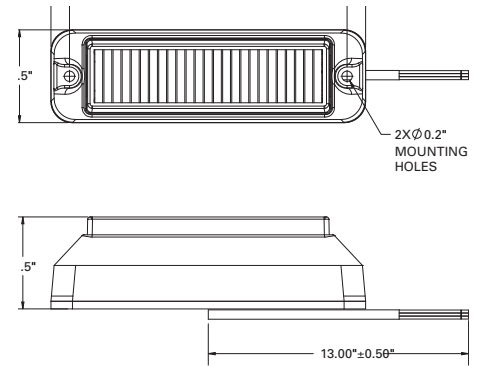

FEATURES AND BENEFITS

Compact versatile Class I LED directional light is ideal for applications requiring high intensity output with low current draw. Featuring 4 high-intensity LEDs and clear polycarbonate lens, units are colourless when not illuminated. Warning capability can be customized by selecting from nine (9) flash patterns.

This light also provides the option to synchronize multiple heads simultaneously or alternatively. The epoxy-encapsulated electronics provide environmental protection against dust, moisture and vibration. These LED light heads are rugged in design and can be mounted in a variety of locations on a vehicle.

PRODUCT SPECIFICATIONS

- SAE J595 Class I
- 12VDC, 0.3 AMPS
- 9 flash patterns with 4 integral flash modes (steady burn, double, fast double, quad & quint)
- Temperature Range: -22°F to +122°F (-30°C to +50°C)

PART #	COLOUR	VOLTAGE	AMPS	FLASH PATTERNS
78773	AMBER	12	0.3	STEADY, DOUBLE, QUAD, QUINT, INT-ALT

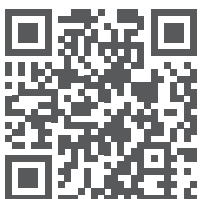

Visit www.grote.com
to view our online
product catalogue

Grote[®]

230 Travail Road, Markham,
Ontario, Canada L3S 3J1
TEL: **800.268.5612**
US: **800.628.0809**
www.grote.com