

XTL® DOME/ TASK LIGHTING

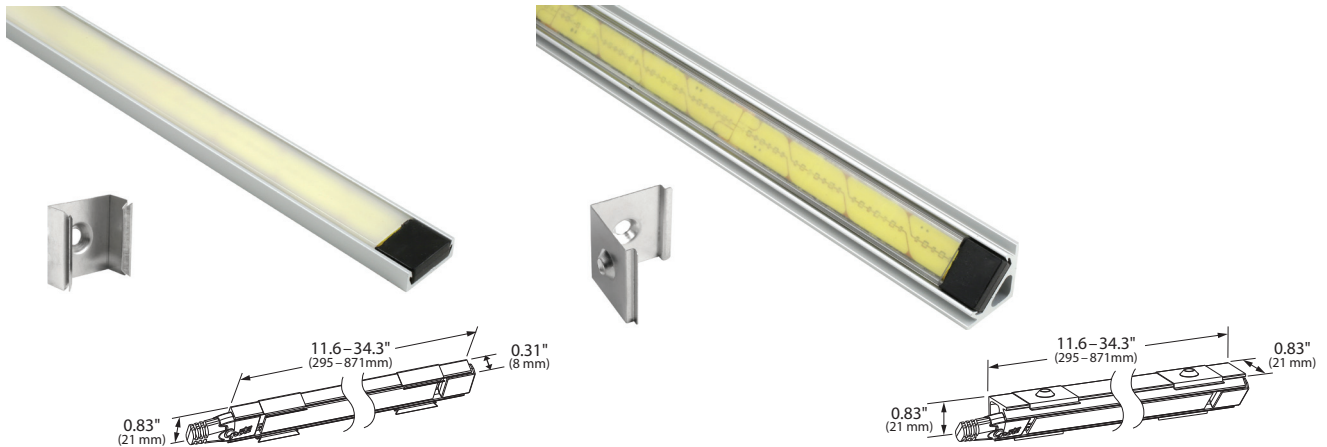

DATA SHEET

TASK LIGHTING



Install XTL® Strip Lighting Where Tape is not Practical.

- Provides ability to install extrusion at 90-degree angle to be able to aim light at a 45-degree angle
- Opaque lens provides a smooth non-glaring light output
- Extrusions protect XTL® Strip Lighting from impacts
- Snap in or slide in lens
- Mounting Clips supplied separately in hardware bag
- Recommendation: use 2 clips on 288mm extrusion, 3 clips on 488mm extrusion, 4 clips on 576mm extrusion, and 5 clips on 864mm extrusion
- 18-8 Stainless-Steel Phillips Flat-Head Screws required for installation (not included)

PRODUCT SPECIFICATIONS

OPERATING TEMPERATURE: -40 to 149F (-40 to 65C)
STORAGE TEMPERATURE: <194 F/ 90C
INPUT VOLTAGE RANGE: +10 to +14 VDC

COMPLIANCES

IMPACT RESISTANCE: SAE J575 sec. 4.3
THERMAL SHOCK: SAE J1455 sec. 4.1.3.2
UV WEATHERING: SAE J2412 & J2527
HUMIDITY: SAE J1455 sec. 4.7
INGRESS PROTECTION: IP67 & IP69K
CORROSION: SAE J2139
VIBRATION: SAE J575 sec. 4.2
FLAMMABILITY: FMVSS 302
CHEMICAL RESISTANCE: SAE J1455 sec 4.4*
ABRASION: SAE J1455 sec. 4.8 & J400
REVERSE POLARITY: SAE J2139
STATIC DISCHARGE: SAE J1113
HUMIDITY/TEMPERATURE: SAE J2139
CHEMICAL: J575-4.14

* Battery acid and Freon excluded

PART NUMBER	LENGTH (IN/MM)	LENS TYPE	EXTRUSION TYPE	LUMENS	CURRENT (AMPS @ 13.5V)
61R00	11.33/288	Clear	Angle	630	0.19
61R20	18.89/480	Clear	Angle	1,054	0.33
61R40	22.67/576	Clear	Angle	1,373	0.40
61T60	34.02/864	Clear	Flat	1,912	0.37
61R60	34.02/864	Clear	Angle	1,912	0.37

FOR MORE
INFORMATION
VISIT **GROTE.COM**

Grote Industries, Inc. 2600 Lanier Drive, Madison, Indiana U.S.A. 47250-0550
U.S. **800.628.0809** | Europe **+49 9422 40331-0** | China **+86.21.5774.9633**
Canada **800.268.5612** | Mexico **+(52) 818262 4412**

