

GROTE LED SNOW PLOW HEADLAMP AIMING INSTRUCTIONS

SUPPLIES REQUIRED:

Tools for adjusting your lamp mounts
Tape measure
Tape or String

INCLUDED IN BOX:

Lamp(s)
Pigtail(s)

MAXIMUM TORQUE:

Max torque 20 Nm
(M12 Bolt)

HEATING ELEMENT:

An integrated sensor activates the heating element when the temperature of the lens falls below 35°C (95°F) and deactivates it when it reaches 50°C (122°F) ± 5°C (9°F).

INSTALL LIGHT:

Make sure vehicle is off and battery has been disconnected when installing light.

Properly mount and connect/wire to vehicle's electrical system. (see wiring diagram for included pigtail and lamp functions)

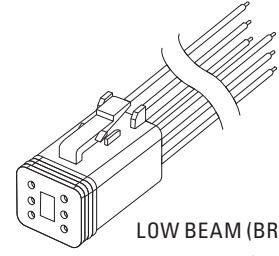

LOW BEAM (BROWN)
HIGH BEAM (RED)
(2) GROUND LINES (WHITE)
POSITION LIGHT (BLUE)
TURN LIGHT (BLACK)

Following installation, Grote headlamps MUST be properly aimed.

The horizontal line of the beam pattern must adhere to all relevant regulations. This can be achieved through securely mounting and accurately aiming the headlamp. It is suggested that outside assistance from a professional should be sought if one is unfamiliar with the legal requirements for mounting and aiming headlamps. Improper headlamp alignment increases risk to other drivers. Local authorities have the right to issue tickets or citations if headlamps fail to meet established regulations. Grote does not assume responsibility, nor is it liable for any citations/tickets received or damage to vehicles or lamps as a result of following these guidelines.

AIMING INSTRUCTIONS:

The lamps are aimed by visually observing the pattern and adjusting it to the correct location. It is best to work in a shaded area, at dusk, or inside. Park vehicle 25' away from a wall/screen on level surface and ensure vehicle is perpendicular to wall/screen (see figures A & C). Now you are ready to aim your lamps.

1. Measure and note the center height from the ground to the center of the lamp you are adjusting (see figure B). Make sure lamps are in driving position (for vehicles with hydraulic lifts).
2. Measure and note the distance between the center of the lamps you are adjusting (see figure B).
3. On wall/screen 25' away from the vehicle, tape or indicate adjustment points (see figure A). It is critical that vehicle is perpendicular to taped wall/screen.
4. Turn on the lamps and block or unplug one of the lamps while aiming the other.
5. Adjust headlight using alignment mechanisms on vehicle or lamp.

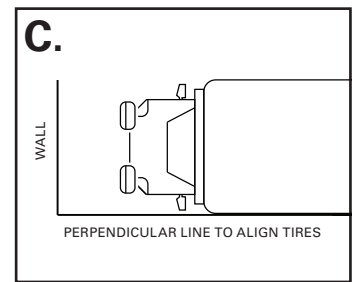
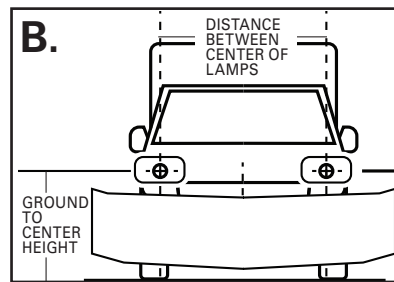
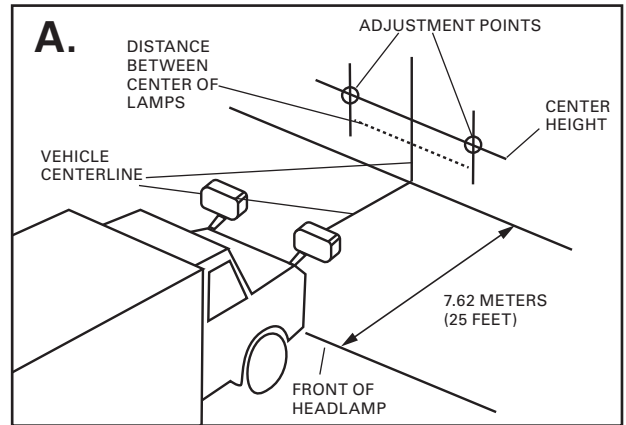

- 5a.** First adjust vertically until hot spot is centered on X axis (see figure D1)

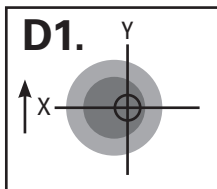

- 5b.** Next adjust horizontally until hot spot is centered on Y axis (see figure D2)

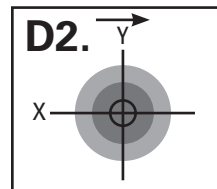

- 6.** Repeat process on all lamps as required, and make sure both head lamp hot spots are centered on marked crosses (see figure D3)

