

LED Amber Warning and Red Stop/Tail/Turn Lamps for Agriculture and Off-Highway Applications

Product Information Sheet

STOP/TAIL/TURN LIGHTING

Surface Mount



Pedestal Mount



Rugged, Reliable, Mount-Anywhere LED Performance

- Lamps and flasher control module meet ANSI/SAE S279.14 specifications and FMVSS requirements
- LED technology offers higher, more efficient, light output and longer life expectancy in severe shock and vibration applications
- Lamps may be mounted right side up, upside down, or vertically and still meet compliance specifications
- IP67 Ingress Protection certified against dust and moisture intrusion
- Single surface mount lamps can be locked together to create double configuration with custom bracket 98130
- Lamps employ bi-voltage circuitry – 12/24 volt
- Possible Applications for these lamps also exist in construction, mining and other off highway markets

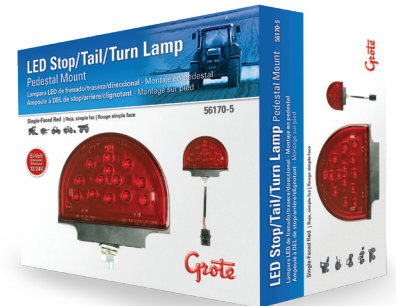

Flasher Control Module Kit #67750

- When using a flasher control module and Grote lamps for towed or mounted implements, the proper Grote flasher module must be used. Use with competitor's module may result in improper function.
- Flasher Control Module Connectors:
 - Power End Packard 12010975
 - Adapter Harness End Packard 12015799
- Adapter Harness Connectors:
 - Flasher Control Module End Packard 12010975-B
 - Lamp End 2-way Packard 12015792, 3-way Packard 12015793



Power Harness #66072

- Connectors:
 - Flasher Control Module Connector Packard 12015799
 - Vehicle End: Blunt Cut (can be terminated with Grote 84-2350 Heat Shrinkable Connectors, and Grote 82-1019 7-way socket/plug connector)

2600 Lanier Drive, Madison, Indiana U.S.A. 47250-0550

U.S. 800.628.0809 Canada 800.268.5612

Europe +49 9422 40331-0 Mexico +(52) 818262 4412 China +86.21.5774.9633

GLB2018-118

grote.com

Grote

LED Amber Warning and Red Stop/Tail/Turn Lamps for Agriculture and Off-Highway Applications

Product Information Sheet

STOP/TAIL/TURN LIGHTING

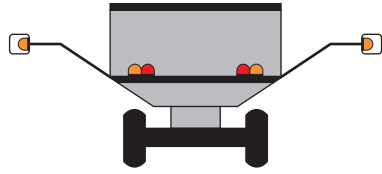

SIDE MOUNT / STANDARD MOUNT

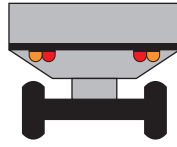

INVERTED DOUBLE MOUNT

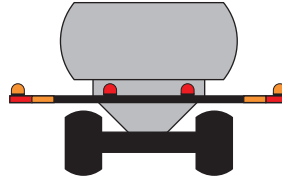

SINGLE MOUNT

HOW DOES THE FLASHER CONTROL MODULE WORK ?

LAMP	DRIVING MODE	TURNING MODE
Amber / Amber Warning Lamps	Flashing In Unison With Tractor. 60-85 Flashes Per Minute	Opposite Of Turn - Lamp is Steady On Turn Side - Flash Rate Increases by 20 Flashes Per Minute
Red / Black Stop/Tail/Turn Lamps	Tail Function In Steady Burn Mode	Opposite Of Turn - Lamp is Steady On Turn Side - Lamp Flashes High Intensity/Low Intensity in Unison with Amber/Amber Lamp

AMBER AND RED LAMP PRODUCT SPECIFICATIONS

MATERIAL: ABS HOUSING/HIGH IMPACT ACRYLIC LENSES
FINISH: AMBER/AMBER; RED/BLACK
ASABE: MEETS ALL ANSI/ASAE S279.14 LIGHTING SPECIFICATIONS
FMVSS: MEETS ALL FMVSS 108 REQUIREMENTS
IP67 COMPLIANT
VOLTAGE: BI-VOLTAGE, 12 AND 24 VOLT
AMPS: RED MAX 0.14A @ 12V (STOP)
 RED MAX 0.08A @ 24V (STOP)
 AMBER MAX 0.56A @ 12V
 AMBER MAX 0.29A @ 24V

FLASHER CONTROL MODULE PRODUCT SPECIFICATIONS

NOMINAL DESIGN VOLTAGE: 12 VDC - 13.8 VDC
HIGH/LOW VOLTAGE LIMITS: 10 VDC - 15VDC
DESIGN CURRENT LOAD: 4 AMPS HIGH FILAMENT OUTPUT (4 TOTAL), 4 AMPS TAIL LIGHT OUTPUT
OVER CURRENT PROTECTION: REQUIRES MAX 15 AMP CUSTOMER FUSE
OPERATING TEMPERATURE: -30°F TO 150°F
HOUSING MATERIAL: COPOLYMER, POLYPROPYLENE, BLACK
MAXIMUM MOUNTING FASTENER SIZE: 1/4"
OPERATION: OPERATES WITH LED AND INCANDESCENT LIGHTING
WIRING: 16 GA GPT WITH UV INHIBITOR
 COMPLIANT WITH SAE J1128

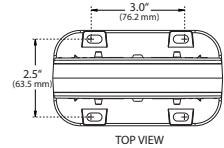

TOP VIEW

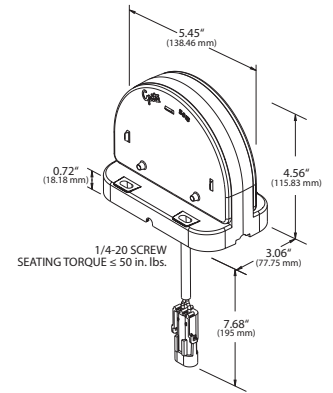

1/4-20 SCREW SEATING TORQUE ≤ 50 in. lbs.

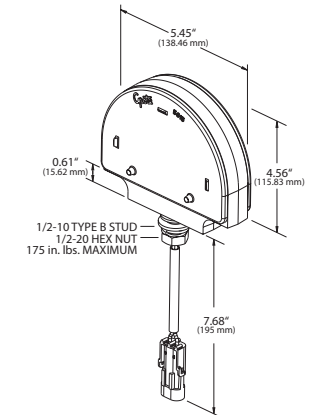

1/2-10 TYPE B STUD 1/2-20 HEX NUT 175 in. lbs. MAXIMUM

Part Number	Description	Mounting Configuration	Termination
56150-5	LED Amber/Amber Warning	Pedestal	Packard 12010973
56160-5	LED Amber/Amber Warning	Surface	Packard 12010973
56170-5	LED Red/Black Stop/Tail/Turn	Pedestal	Packard 12010717
56180-5	LED Red/Black Stop/Tail/Turn	Surface	Packard 12010717
67750	Flasher Control Module Kit		See page one
66072	Power Harness		See page one
82-1019	7-Way Socket / Plug Connector		
84-2350	Heat Shrinkable Connectors		
98130	Lamp Adapter Bracket Kit		

2600 Lanier Drive, Madison, Indiana U.S.A. 47250-0550

U.S. 800.628.0809 Canada 800.268.5612

Europe +49 9422 40331-0 Mexico +(52) 818262 4412 China +86.21.5774.9633

grote.com

