

S100 LED WhiteLight™ Motion Sensing Surface Mount Dome Lamp

Product Information Sheet

INTERIOR LIGHTING

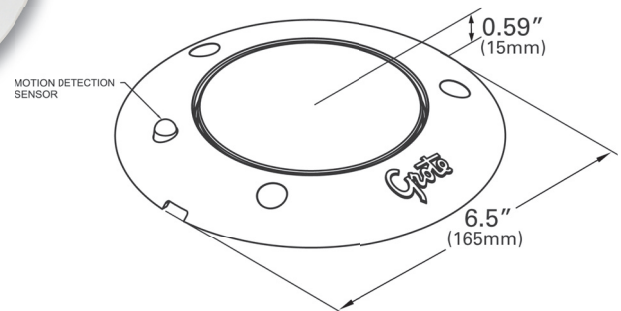

- 300 lumens of output utilizing the latest LED WhiteLight™ technology

PRODUCT FEATURES AND BENEFITS

- Low profile sleek design is less than .6" (15.0 mm) in height and operates at -40F to +122F, -20 for the motion sensor lamp
- Infrared human motion detection sensor (61411 and 61421) turns on lamp within 10 feet; eliminating the need for additional switches
- Rugged, surface mountable, one piece moulded lamp allows for a moisture-proof construction and a wide variety of uses while passing IP69
- Stylish polycarbonate UV coated design hugs the ceiling to resist "knock-offs"
- Q current is less than 2ma for constant motion sensing
- ECE R10, Dir. 72 / 245 / EEC, Amended by 2006 / 28 / EC

PRODUCT SPECIFICATIONS

MATERIAL: POLYCARBONATE
FINISH: WHITE
VOLTAGE AMP: 12V / .7A; 24V / .38A

Part Number	Market	Light Source	Operating Voltage	Amperage	Interchange
61391 S100	Truck/Trailer	LEDs	12V	.7A	NA
61401 S100, 24-Volt	Truck/Trailer	LEDs	24V	.38A	NA
61411 S100 w / Motion Sensor	Truck/Trailer	LEDs	12V	.7A	NA
61421 S100 w / Motion Sensor, 24-Volt	Truck/Trailer	LEDs	24V	.38A	NA

grote.com

2600 Lanier Drive, Madison, Indiana U.S.A. 47250-0550

U.S. 800.628.0809 Canada 800.268.5612



The first name in vehicle safety systems®